

- █ █ Istruzioni per il montaggio e l'installazione che devono essere seguite per l'utilizzo corretto delle barre parallele 260208. Obbligo di ancoraggio al pavimento in applicazione della norma UNI EN 12182 (2012).
- █ █ Instructions à suivre impérativement pour l'assemblage, l'installation et l'emploi correcte des barres parallèles 260208. Obligation de fixer au sol, selon la norme NF EN 12182 (2012).
- █ █ It is imperative to follow the instructions below to assure correct assembly, installation as well as correct use of the parallel bars 260208. Obligation to anchor to the floor, according to DIN EN 12182 (2012).
- █ █ Die folgenden Anweisungen sind verpflichtend um eine sachgerechte Montage, Installation und Verwendung des Gehbaren 260208 zu versichern. Verpflichtung zur Fixierung am Boden, nach Richtlinie DIN EN 12182 (2012).

Ref: ART. 260208

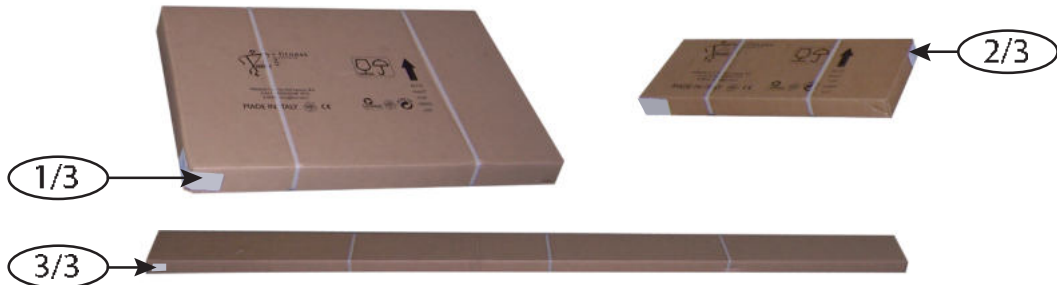

TOT. : 3

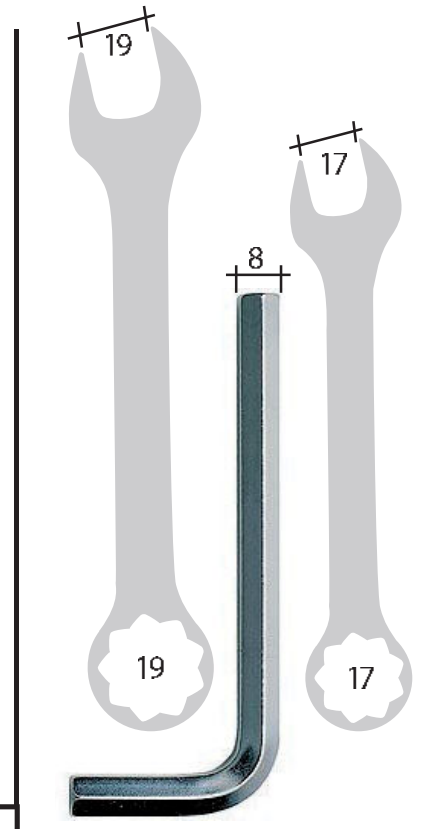
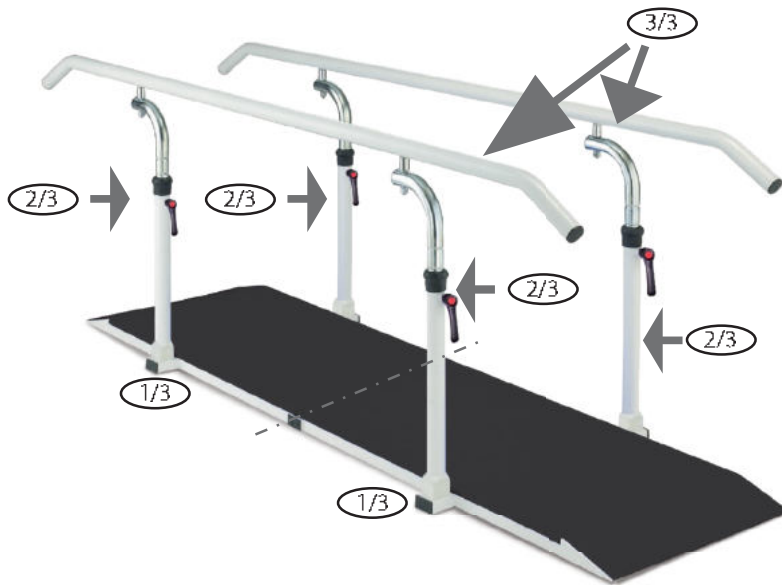

nel collo / inclus dans la boîte / included in box / im Lieferkarton enthalten



nel collo / inclus dans la boîte / included in box / im Lieferkarton enthalten

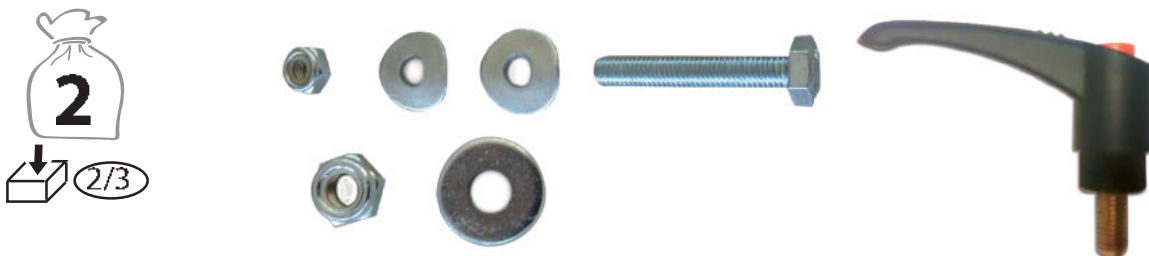

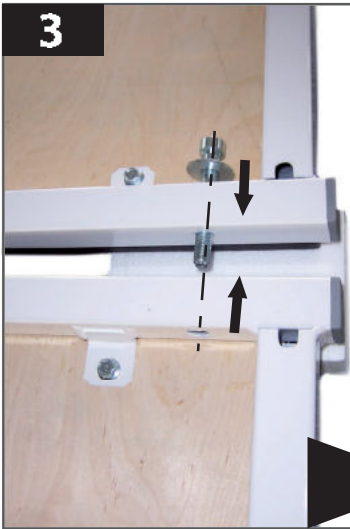
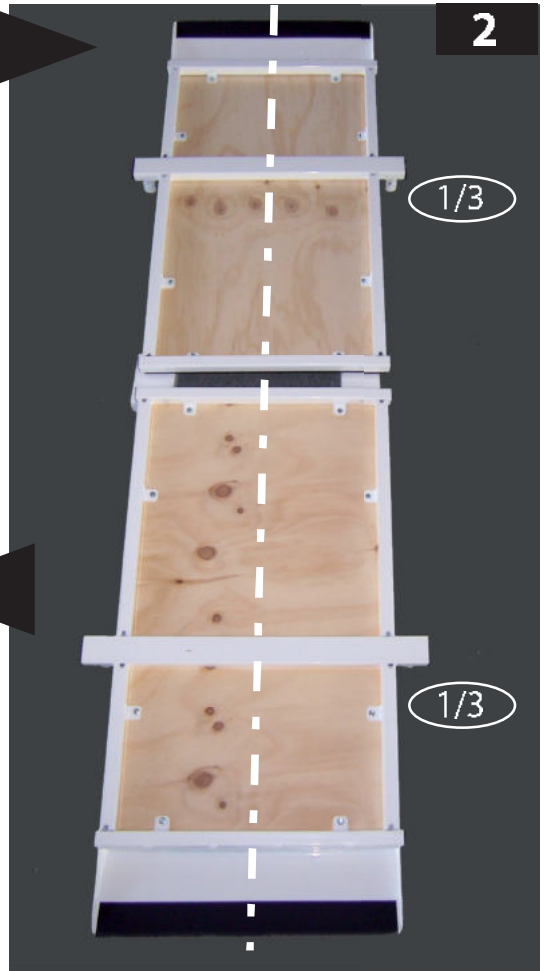

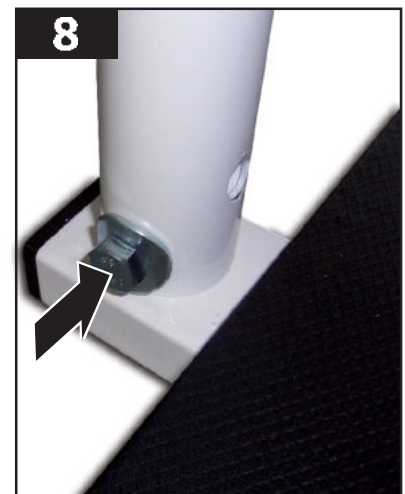
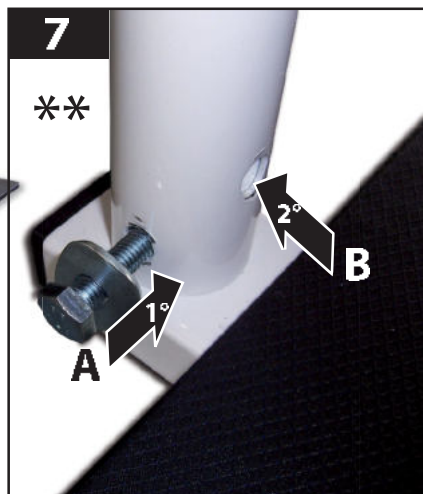
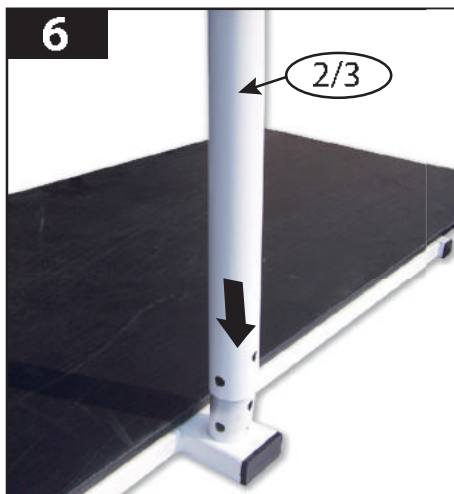

- UNIRE IL SUPPORTO BIANCO ALL'APPOSITO ANCORAGGIO SUL PIANO DI CAMMINAMENTO
- INSERIRE IL PERNO FILETTATO CON RONDELLA CONCAVA ALL'INTERNO DEL FORO PIÙ IN BASSO (A)
- FIXER LE TUBE DE SOUTIEN BLANC, CYLINDRIQUE, À SON SUPPORT SUR LE SOCLE,
- FAIRE PASSER LA VIS AVEC SA RONDELLE CONCAVE À L'INTÉRIEUR DU TROU PLUS BAS (A)
- INSERT THE WHITE CYLINDRICAL SUPPORT TUBE INTO THE DESIGNATED FITTING ON THE BASE
- INSERT THE SCREW WITH ITS CONCAVE WASHER INTO THE BOTTOM HOLE (A)
- BEFESTIGEN SIE DIE WEIßE ZYLINDERFÖRMIGE ROHRSTÜTZE AN DER VORGEGEHEHENEN BEFESTIGUNG AM SOCKEL
- FÜHREN SIE DIE SCHRAUBE MIT SEINER KONKAVEN UNTERLEGSCHIEBE IN DAS UNTERSTE LOCH EIN (A)



ATTENZIONE: PER IL CORRETTO FISSAGGIO È INDISPENSABILE INIZIARE IL FISSAGGIO, A PARTIRE DAL FORO PIÙ IN BASSO

ATTENTION: POUR L'INSTALLATION CORRECTE IL EST INDISPENSABLE DE COMMENCER L'INSTALLATION A' PARTIR DU TROU PLUS BAS (A)

NOTE: TO ENSURE CORRECT ASSEMBLY OF THE ITEM IT IS NECESSARY TO START AT THE BOTTOM HOLE AND PROCEED FROM THERE UPWARDS

ACHTUNG: FÜR EINE ORDNUNGSGEMÄßE INSTALLATION IST ES NOTWENDIG DIE INSTALLATION VOM UNTERSTEN LOCH HER ZU BEGINNEN

**

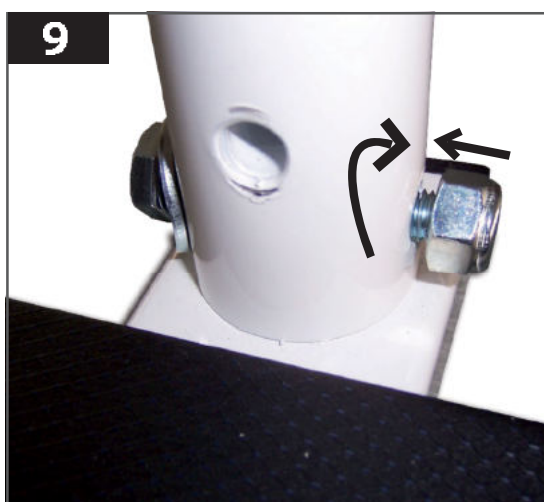

- AVVITARE IL DADO FINO IN FONDO PER CONSENTIRE ALLA RONDELLA CONCAVA DI ADATTARSI ALLA SUPERFICIE
- VISSER L'ÉCROU LE PLUS POSSIBLE POUR QUE LA RONDELLE CONCAVE SOIT AJUSTÉ À LA SURFACE DU TUBE
- FASTEN THE NUT WELL SO THAT THE CONCAVE WASHER SITS TIGHTLY ON THE SURFACE OF THE TUBE
- ZIEHEN SIE DIE MUTTER GUT FEST, SODASS DIE KONKAVE UNTERLEGSCHIEBE AUF DER OBERFLÄCHE DES ROHRES FEST AUFLIEGT



- ESTRARRE NUOVAMENTE IL DADO
- ENLEVER L'ÉCROU DE NOUVEAU
- UNSCREW THE NUT AGAIN
- SCHRAUBEN SIE DIE MUTTER WIEDER AB

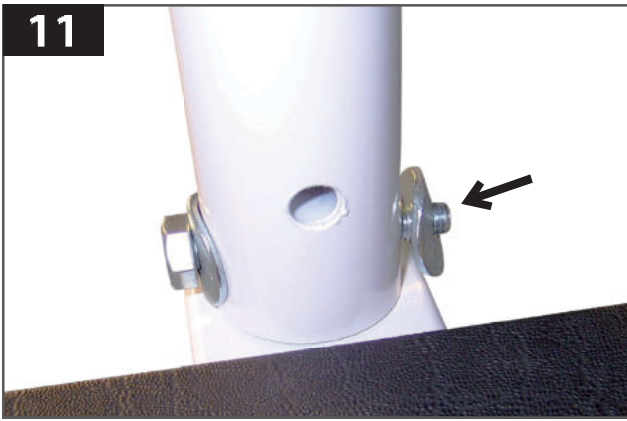

- INSERIRE L'ALTRA RONDELLA CONCAVA A LATO OPPOSTO
- METTRE L'AUTRE RONDELLE CONCAVE SUR LE CÔTE 'OPPOSE'
- FIT ANOTHER CONCAVE WASHER TO THE OPPOSITE SIDE
- SETZEN EINE WEITERE KONKAVE UNTERLEGSCHIEBE AUF DER GEGENÜBERLIEGENDEN SEITE AUF

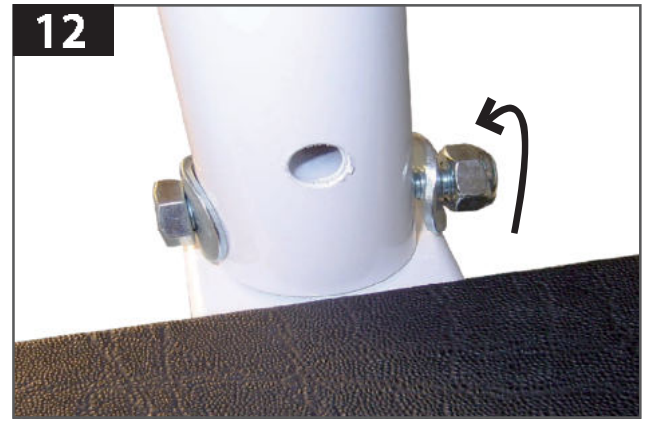

- RIMETTERE IL DADO ED AVVITARE FINO ALLA PERFETTA CHIUSURA
- REMETTRE L'ÉCROU ET VISSER JUSQU'A SA PARFAITE FERMETURE
- PUT THE NUT ON THE SCREW AGAIN AND TIGHTEN AS FAR AS IT WILL GO
- SETZEN SIE DIE MUTTER WIEDER AUF UND SCHRAUBEN SIE DIESE BIS ZUM ANSCHLAG FEST

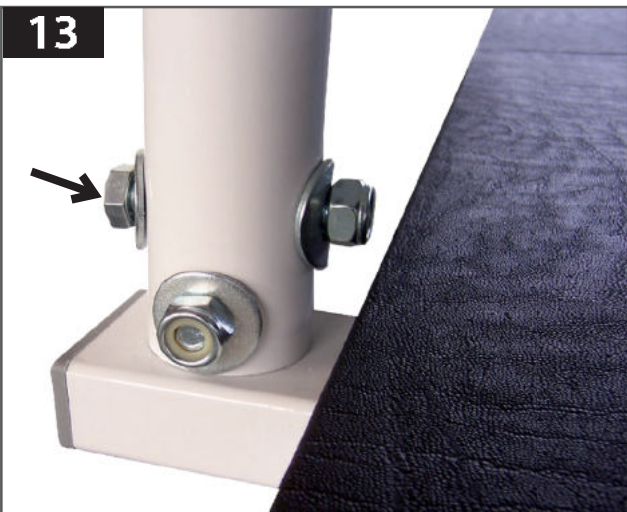

- RIPETERE LE OPERAZIONI PRECEDENTI ANCHE PER I PERNI SUPERIORI
- RÉPÉTER LES ÉTAPES DE TRAVAIL POUR LES VIS SUPÉRIEURS
- REPEAT THE PROCEDURE FOR THE UPPER SCREWS
- WIEDERHOLEN SIE DIE ARBEITSSCHRITTE FÜR DIE OBEREN SCHRAUBEN



- COMPLETARE L'OPERAZIONE APPLICANDO I COPRIDADO IN DOTAZIONE
- POUR FINIR, METTRE LES CACHES BLANCHES LIVRÉES AVEC
- TO FINISH, FIT THE WHITE COVERINGS INCLUDED IN DELIVERY
- MONTIEREN SIE ZUM ABSCHLUSS DIE IM LIEFERUMFANG ENTHALTENEN WEIßEN ABDECKUNGEN



- E QUINDI SU TUTTI I QUATTRO SUPPORTI DEI CORRIMANO
- SUIVRE LA MÊME PROCÉDURE POUR LE MONTAGE DE TOUTS LES TUBES DE SOUTIEN BLANCS
- PROCEED AS DESCRIBED ABOVE TO ANCHOR ALL OTHER WHITE SUPPORT TUBES
- GEHEN SIE WIE OBEN BESCHRIEBEN FÜR DIE BEFESTIGUNG ALLER WEIßEN ROHRSTÜTZEN VOR

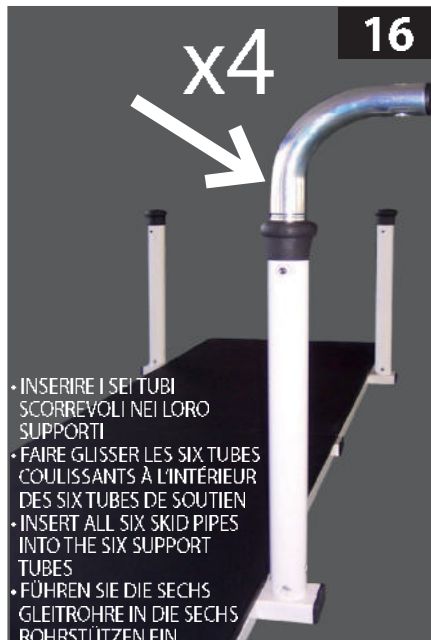

- INSERIRE I SEI TUBI SCORREVOLI NEI LORO SUPPORTI
- FAIRE GLISSER LES SIX TUBES COULISSANTS À L'INTÉRIEUR DES SIX TUBES DE SOUTIEN
- INSERT ALL SIX SKID PIPES INTO THE SIX SUPPORT TUBES
- FÜHREN SIE DIE SECHS Gleitrohre IN DIE SECHS ROHRSTÜTZEN EIN



- APPLICARE I BLOCCAGGI DEGLI SCORREVOLI NELL'APPOSITA SEDE
- APPLIQUER UNE MANETTE DE SERRAGE SUR LE CÔTÉ DE CHAQUE TUBE DE SOUTIEN
- FIT ONE BOLT LEVER TO THE SIDE OF EACH SUPPORT TUBE
- BRINGEN SIE JEWEILS EINEN SPANNHEBEL AUF DER SEITE EINER ROHRSTÜTZE AN

APRIRE - OUVRIRE **CHIUDERE - FERMER**
OPEN - ÖFFNEN **CLOSE - SCHLIESSEN**

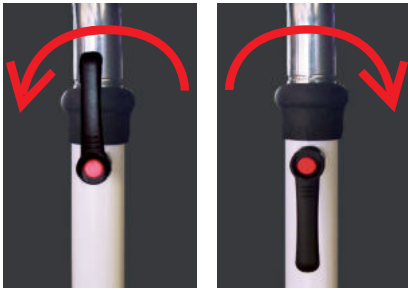

- POSIZIONE DELLA LEVA DA RISPETTARE PER APRIRE/CHIUDERE
- POSITION DE LA MANETTE EN POSITION OUVERT/FERME'
- OPEN / CLOSED POSITIONS OF THE BOLT LEVER
- POSITIONEN DES SPANNHEBELS OFFEN / GESCHLOSSEN



NO/NON
NO/NEIN



NO/NON
NO/NEIN



SI/OUI
YES/JA

- POSIZIONE CORRETTA CHE LA LEVA DEVE AVERE DOPO AVERE BLOCCATO GLI SCORREVOLI
- POSITION CORRECTE QUE LA MANETTE DOIT OCCUPER POUR BLOQUER LES TUBES COULISSANTS
- CORRECT POSITION OF THE BOLT LEVER TO LOCK THE SKID PIPE IN PLACE
- RICHTIGE POSITION DES SPANNHEBELS UM DIE GleITROHRE ZU ARRETIEREN

18

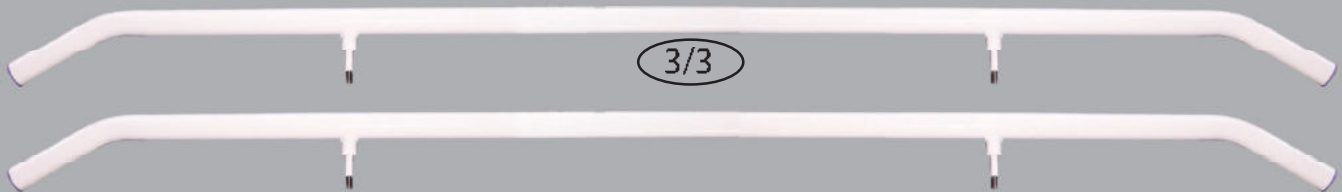

- PRELEVARE I CORRIAMANO DAL LORO IMBALLO
- ENLEVER L'EMBALLAGE DES MAINS COURANTES

- REMOVE THE PACKAGING MATERIAL FROM THE HANDRAILS
- ENTFERNEN SIE DAS VERPACKUNGSMATERIAL VON DEN HANDLÄUFEN

19



20

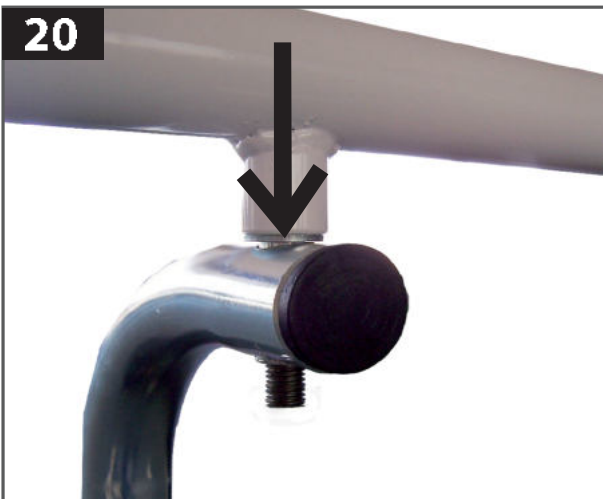

21

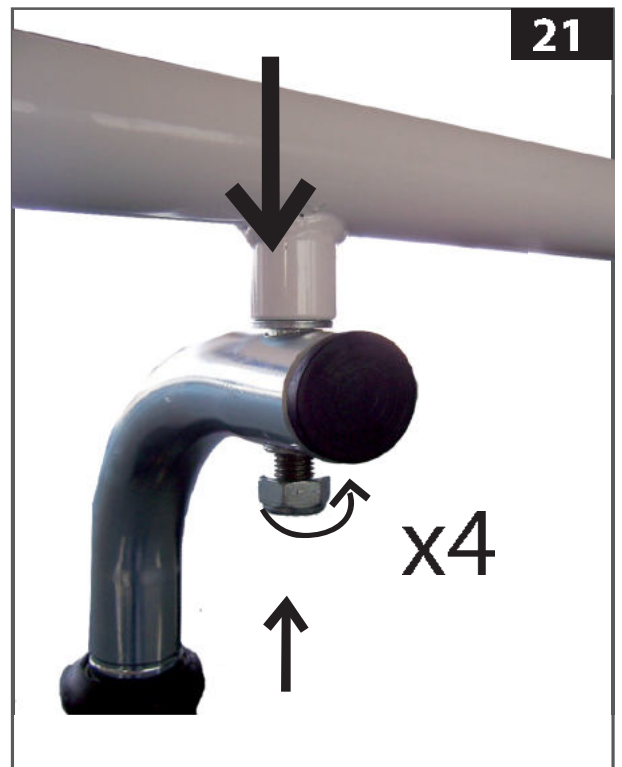

- ASSICURARE I DUE CORRIAMANO NELLE APPOSITE SEDI MEDIANTE I DADI FORNITI ALLO SCOPO
- FIXER LES DEUX MAINS COURANTES DANS LEUR SIÈGE AU MOYEN DES EROUS LIVRÉS AVEC.
- FIX BOTH HANDRAILS IN THE INTENDED POSITION USING THE NUTS INCLUDED IN DELIVERY
- BEFESTIGEN SIE DIE BEIDEN HANDLÄUFE IN DER VORGEGEHEHENEN POSITION MIT HILFE DER IM LIEFERUMFANG ENTHALTENEN SCHAUBMUTTERN



INSTALLAZIONE DEL CORRIMANO - INSTALLATION BARRES PARALLELES
ASSEMBLY OF PARALLEL BARS - MONTAGE DER GEHBARREN

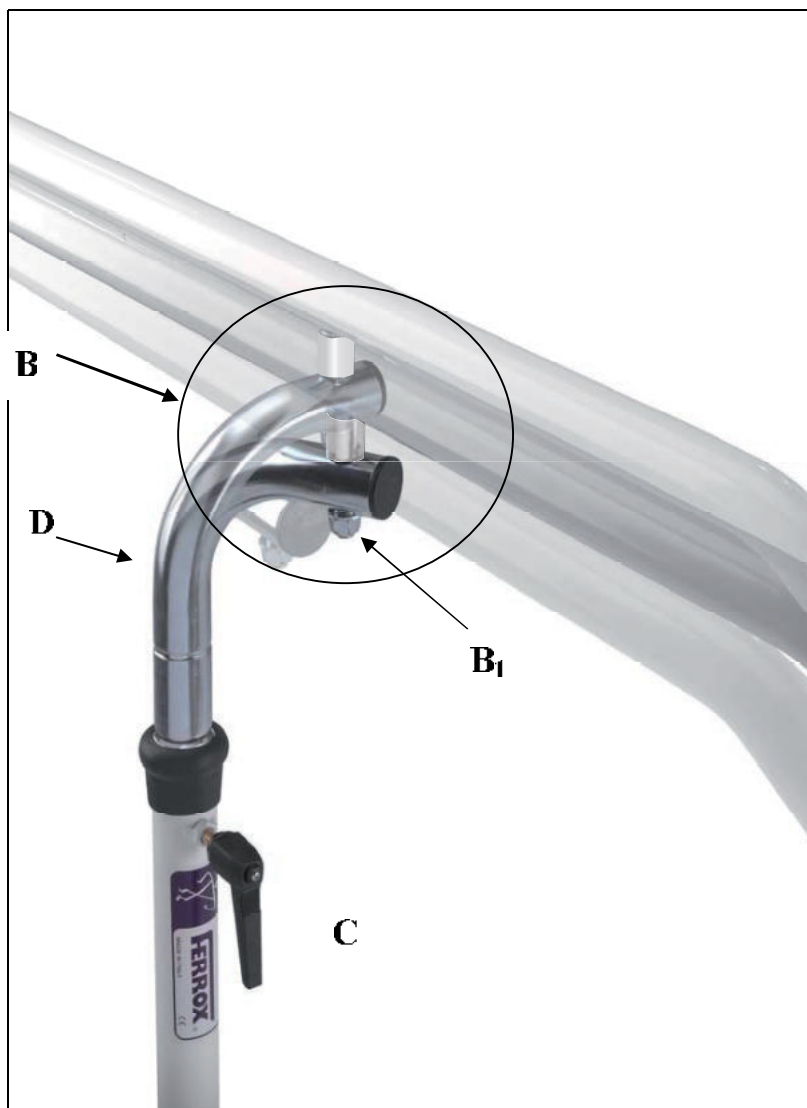

- SCOPO DELL'INSIEME (B) È L'ANCORAGGIO DEL CORRIMANO AL SUPPORTO SCORREVOLE (D). IL DADO (B1) DEVE ESSERE CHIUSO **SENZA**, TUTTAVIA, IMPEDIRE LA ROTAZIONE DEL CORRIMANO PER LA REGOLAZIONE IN LARGHEZZA.
- LA REGOLAZIONE DELLA LARGHEZZA SI EFFETTUA ALLENTANDO LA LEVA (C) E SPINGENDO, PER ACCOMPAGNARLO (VERSO DESTRA O SINISTRA), IL SUPPORTO CROMATO (D).
- LE BUT DE L'ENSEMBLE (B) EST DE FIXER LA MAIN COURANTE A' SON APPUI. L'ÉCROU (B1) DOIT ÊTRE SERRE **SANS**, TOUT DE MÊME EMPÊCHER LA ROTATION DE LA MAIN COURANTE POUR SON RÉGLAGE EN LARGEUR. LE RÉGLAGE DE LA LARGEUR EST FAIT EN DESSERRANT LE LEVIER (C) ET EN POUSSANT (VERS DROITE OU GAUCHE) LE SUPPORT CHROME' (D).
- THE ASSEMBLED PARTS (B) PROVIDE FOR THE FIXATION OF THE HANDRAIL TO ITS SUPPORTING STAND. SCREW-NUT (B1) HAS TO BE TIGHTENED **WITHOUT** IMPEDING THE ROTATION OF THE HANDRAIL, TO ALLOW FOR ITS ADJUSTMENT IN BREADTH. FOR ADJUSTMENT IN BREADTH, RELEASE LEVER (C) AND GENTLY PUSH AND TURN (TO THE LEFT/RIGHT) CHROMED SUPPORT (D).
- ZUSAMMENSTELLUNG (B) SOLL DIE BEFESTIGUNG DES HANDLAUFS AM STÄNDER GEWÄHRLEISTEN. SCHRAUBENMUTTER (B1) MUSS FESTGEZOGEN SEIN, OHNE DIE ROTATION ZUR BREITENVERSTELLUNG DES HANDLAUFS ZU VERHINDERN. FÜR DIE BREITENVERSTELLUNG WIRD HEBEL (C) GELÖST UND DIE VERCHROMTE STÜTZE (D) DURCH LEICHTE STÖBBEWEGUNGEN (NACH RECHTS ODER LINKS) GEDREHT.



INSTALLAZIONE DEL CORRIMANO - INSTALLATION BARRES PARALLELES ASSEMBLY OF PARALLEL BARS - MONTAGE DER GEHBARREN

Disegno 1 - Dessin 1
Figure 1 - Abbildung 1

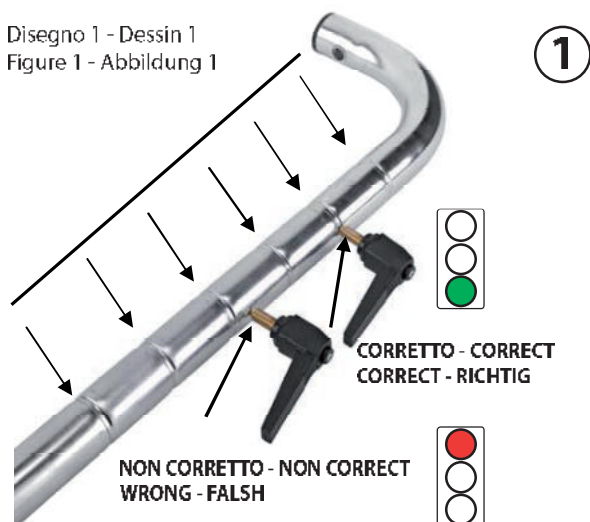

L'ALTEZZA DEL CORRIMANO È REGOLATA CORRETTAMENTE, E MESSA IN SICURTÀ, UNICAMENTE QUANDO LA LEVA DI CHIUSURA SI TROVA ALL'INTERNO DEL SOLCO DI FISSAGGIO.

LA HAUTEUR DE LA BARRE PARALLÈLE EST FIXÉE CORRECTEMENT, ET SÉCURISÉE, UNIQUEMENT LORSQUE LE LEVIER DE SERRAGE SE TROUVE À L'INTÉRIEUR DU CRAN (ENCOCHE) D'ARRÊT.

THE HEIGHT OF THE PARALLEL BARS IS CORRECTLY AND SECURELY ADJUSTED, ONCE THE FASTENER TIGHTLY **SITS IN ONE** OF THE SPECIFICALLY DESIGNED NOTCHES.

DIE HÖHE DES GEHBARRENS IST NUR DANN RICHTIG UND SICHER EINGESTELLT, WENN DER KOPF DES SPANNHEBELS **1** DER VORGESEHENEN KERBE SITZT.

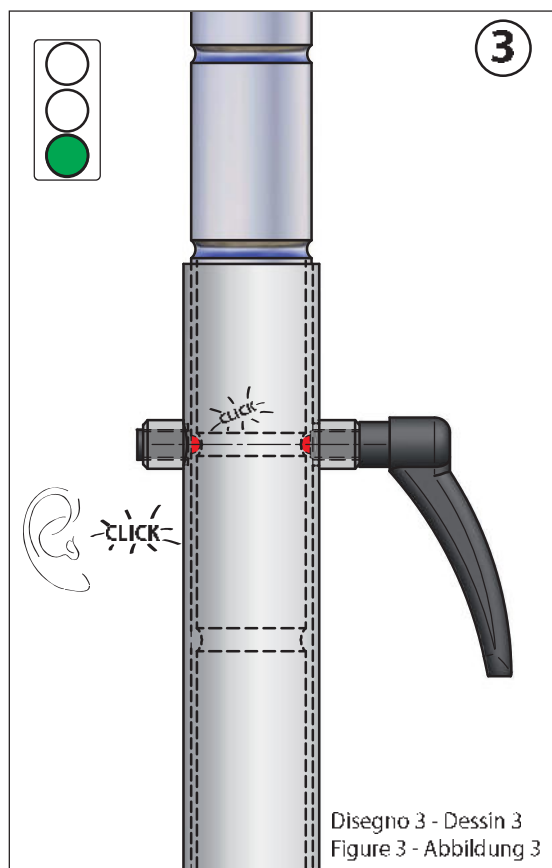
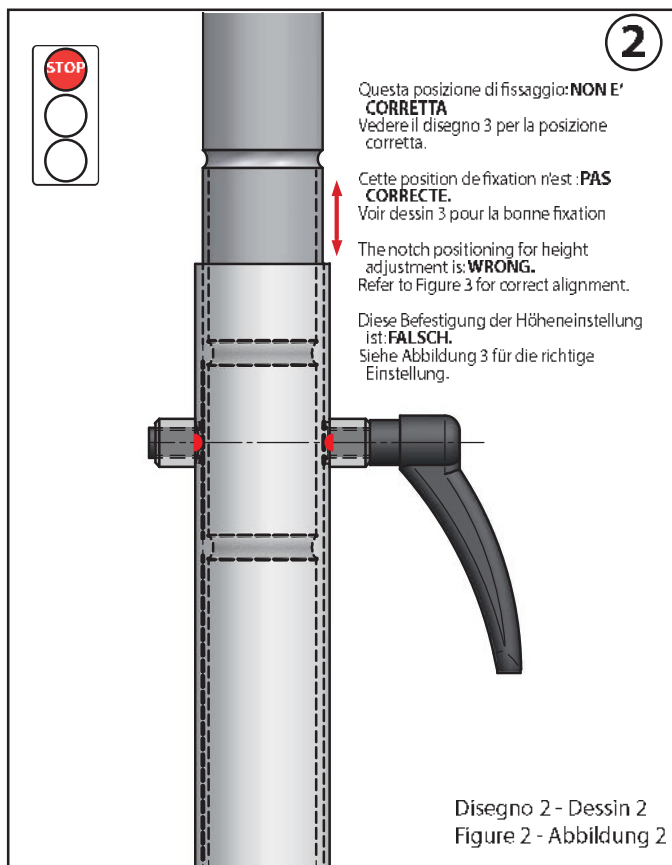

Questa posizione (livello) di fissaggio: **È CORRETTA**.
In questa posizione, la leva (A) si trova nella buona condizione per posizionarsi all'interno del solco di arresto inferiore

Cette position (niveau) de fixation: **EST CORRECTE**.
En cette position le levier (A) se trouve dans la bonne condition pour se positionner à l'intérieur du cran d'arrêt inférieur.

The notch positioning for height adjustment is: **CORRECT**.
In this alignment the fastener (A) is correctly positioned to snap in the designated notch.

Diese Befestigung der Höheneinstellung ist: **RICHTIG**.
In dieser Einstellung befindet sich der Hebel (A) auf der richtigen Höhe, um in der vorgesehenen Kerbe einrasten zu können.

**CHIUDERE - FERMER
CLOSE - SCHLIESSEN**



22



• TERMINARE L'ASSEMBLAGGIO RIPETENDO GLI STESSI PASSAGGI ESEGUITI ANCHE PER IL CORRIMANO OPPOSTO

• POUR FINIR L'ASSEMBLAGE RÉPÉTER LA MÊME PROCÉDURE POUR LA MAIN COURANTE OPPOSÉE

• TO FINISH THE INSTALLATION OF THE PARALLEL BARS, ASSEMBLE THE OPPOSITE HANDRAIL BY REPEATING THE ABOVE PROCEDURE

• UM DIE INSTALLATION ABZUSCHLIEßEN, MONTIEREN SIE DEN GEGENÜBERLIEGENDEN HANDLAUF NACH DER OBEN BESCHRIEBENEN VORGEHENSWEISE

23

• ASPETTO CHE AVRÁ ASSUNTO LA PARALLELA DOPO CHE L'ASSEMBLAGGIO DEL CORRIMANO SARÁ STATO ESEGUITO

• VUE DE LA BARRE PARALLELE APRES QUE LES MAINS COURANTES AURONT ÉTÉ CORRECTEMENT INSTALLÉES

• VIEW OF THE PARALLEL BARS WITH THE HANDRAILS CORRECTLY INSTALLED

• ANSICHT DES GEHBARRENS MIT KORREKT INSTALLIERTEN HANDLÄUFEN



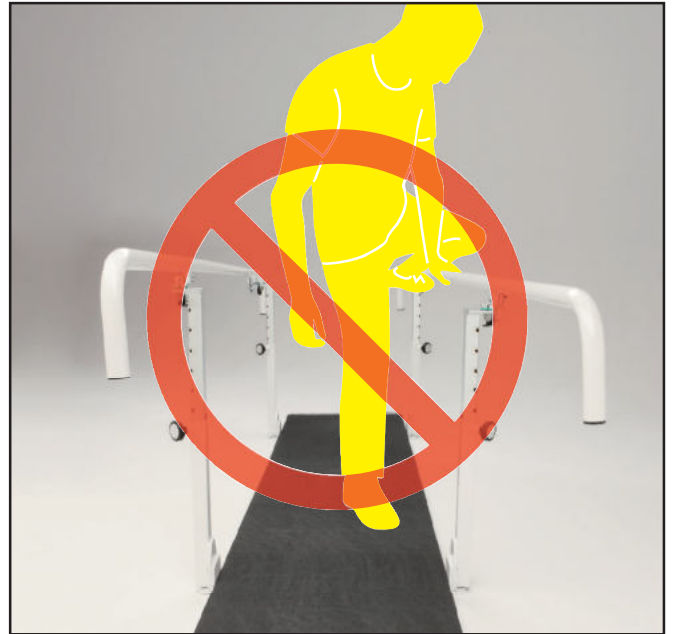

via del Lavoro,9 Z.I. - 31013 Codogné (TV) Italia
Tel. +39 0438 777099
Fax +39 0438 777091
e-mail: info@ferrox.it www.ferrox.it