

Assembling Instruction

Pommel Horse (Art. 218)



Before assembling:

Please read following instructions carefully **before** attempting to assemble.

We recommend 2 people for assembly.

The following components are enclosed:

1 horse body with 2 Aluminium pommels
1 pair of legs
1 fixing chain

Assembly of legs with the body

Place the body on the floor, upper side down.
Adjust the bases between the fixing plates.
Fix the base with the body with the bolts.

Adjustment of the Apparatus:

You can adjust the pommels with the handels. Tighten the pommels after adjusting.
Height adjustment: pull the fixing pin after loosen the fixing lever. Make shure, that the fixing pin fit in the adjustment tube.

Warning:

Each time before an apparatus is used, make sure that it is properly set up and the cables have the appropriate tension. Always use the prescribed matting. A qualified instuctor should be present at all times.

Care Instructions:

From time to time all moving parts should be cleaned of magnesia chalk and lightly greased. Loose steel wires on the tension cables are a danger.

The FIG recommends to fix the pommle horse on the floor with a chain.

Matting:

The International Gymnastic Federation recommends for competitions mats that are 10 cm thick. 4 SPIETH - Mats "Original Reuther" 200 x 200 x 10 cm are appropriate.

Pommel Horse

FIG-Specifications, Mats and carpet cover

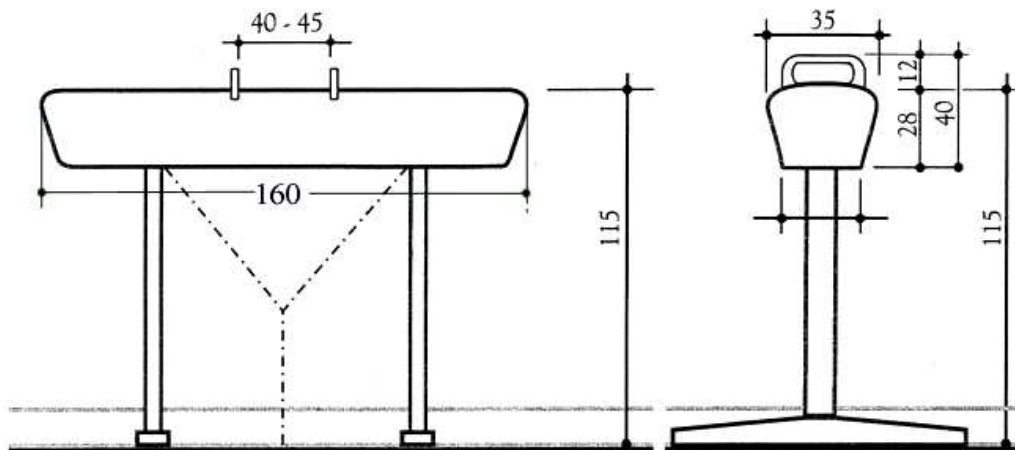

Pommel Horse Mat Set

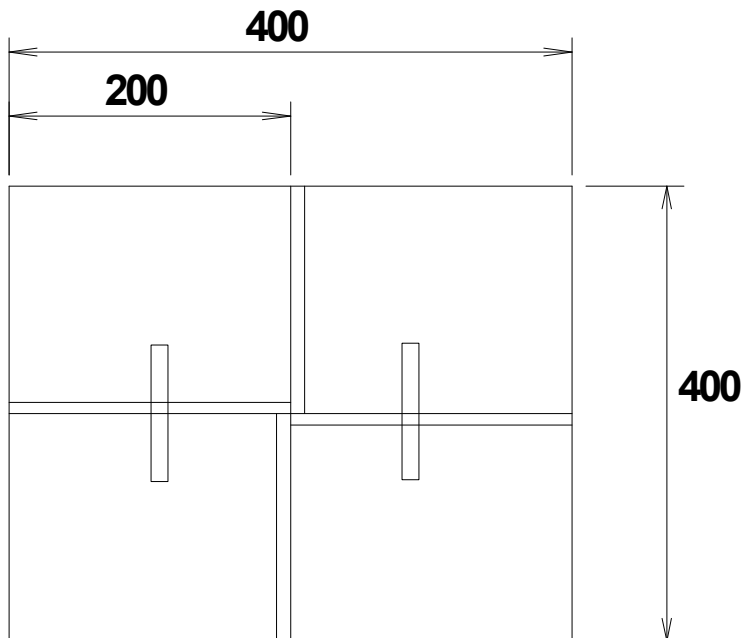

WARNING

Any activity involving motion or height creates the possibility of serious injury including permanent paralysis and even death from landing or falling on the neck or head or other parts of the body.

You assume a risk of serious injury in using this equipment. However, the risk can be reduced by strictly following these rules at all times.

1. Use this equipment only under the supervision of a trained and qualified instructor.
2. This equipment must be used only when protected by proper matting as recommended for each piece of equipment by the International Gymnastic Federation. If doubt concerning proper matting, do not use this equipment.
3. This equipment must be used with proper spotting equipment and qualified instructors suitable to the activity or skill. Always consult an instructor.
4. Know your own limitations and the limitations of this equipment. Follow progressive learning techniques and always consult an instructor.
5. Always inspect this equipment for proper stability before each use.
6. Always inspect this equipment for loose fittings, loose cables and lock before each use. Replace any worn, defective or missing parts.
7. Always inspect this equipment for improper or unsafe installation. If in doubt, do not use this equipment.