

Assembling Instruction

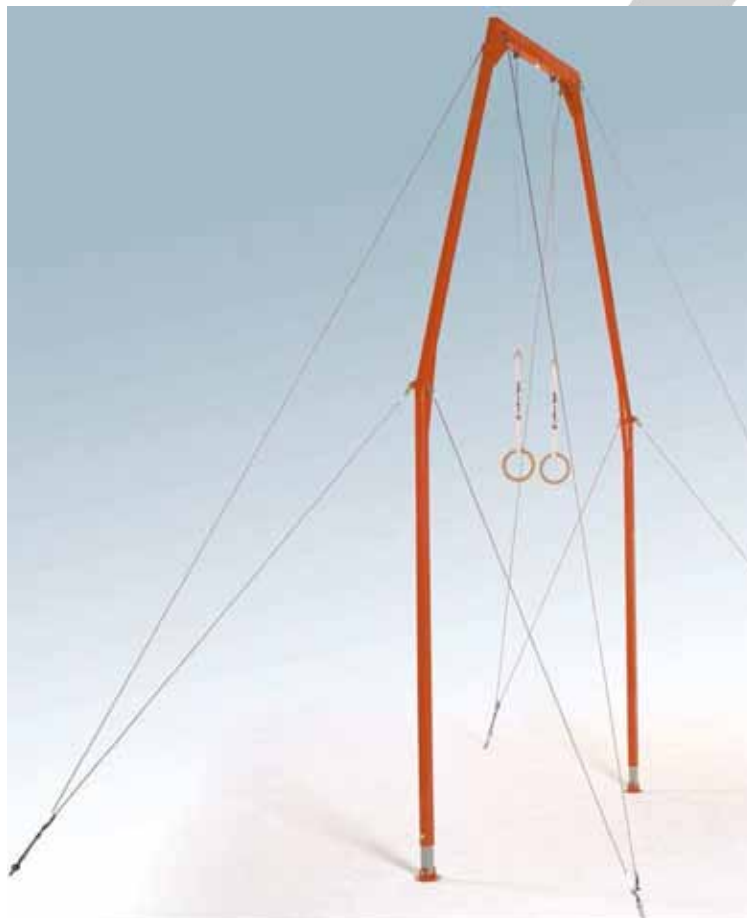

Assembling Instruction

Ring Frame “Barcelona” (Art. 190)



Before assembling:

Please read this instructions thoroughly **before** attempting assembling.
We recommend a minimum of 6 people to adjust the ring frame.

Assembling Instruction



The following components are enclosed in 2 boxes:

- 1 traverse with rings and cables
- 2 upper lateral beam parts
- 2 middle lateral beam parts
- 2 lower lateral beam parts with adjusting pins
- 2 adjustment tubes
- 2 base plates
- 4 cables with slide adjusters and pulley holders
- 4 chains with turnbuckles

Assembly of base with adjustment tubes

Fasten the base plates to the adjustment tubes as shown in the figure. Tighten the screws. Lead the adjustment tubes into the lower lateral beam parts and chose height of pins in the desired hole position.

Assembly of the apparatus

Connect traverse, upper lateral beam parts, middle lateral beam parts, lower lateral beam parts and place the device on floor. Fit cables onto hooks, while the slide adjusters remain at pulley holder casting position. Control the height of rings and if necessary adjust height by using the precision screws above rings. Make shure, that the safety pin is in right position.

For best result stand up the complete frame with minimum 6 persons. 4 persons hold up the frame while the others connect the chains to the hooks in the floor.

Using slide adjusters

The slide adjusters are tighten when both parts are pushed together. Loosen slide adjusters by pulling the parts apart.

Adjustment of the apparatus

Tighten the cables with the slide adjusters.

Care instructions

From time to time all moving parts should be cleaned of magnesia and lightly greased. Loose steel wires on the tension cables are dangerous. Replace such cables immediately. If the apparatus is not to be disassembled after use, release the tension by pulling down the slide adjusters.

Assembling Instruction



Matting

The international Gymnastic Federation recommends for competition mats that are 20 cm thick. 1 SPIETH mat "Original Reuther" size 200x300x20 cm and 2 mats size 150x200x20 cm appropriate.

Ring Frame

FIG-Specifications, Mats and carpet cover

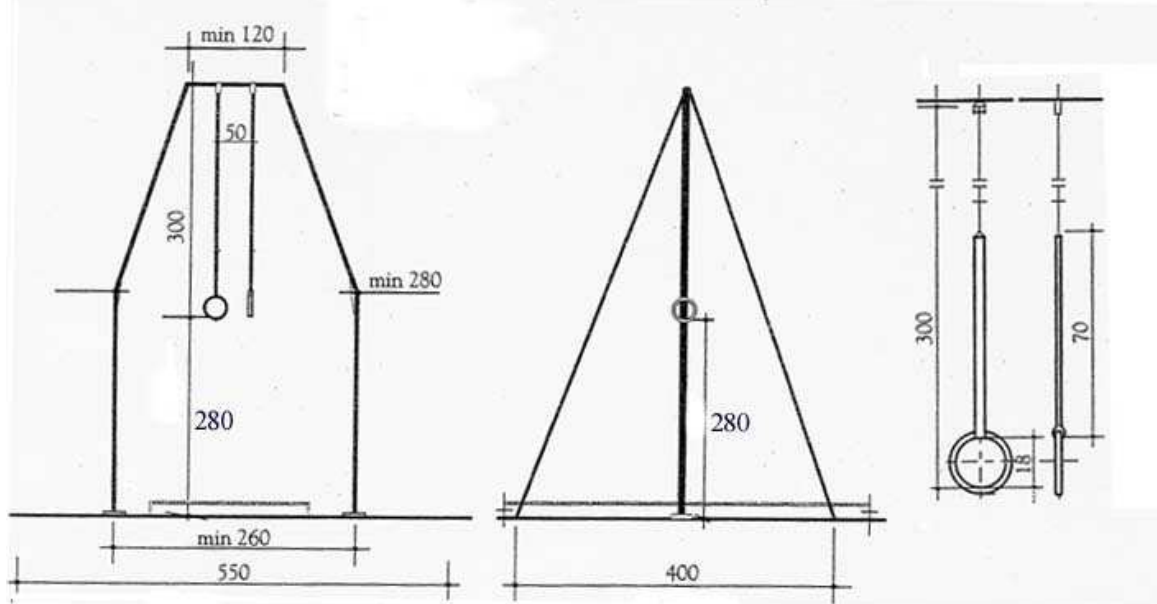

Ringe Mattensatz

Ring Frame Mat-Set

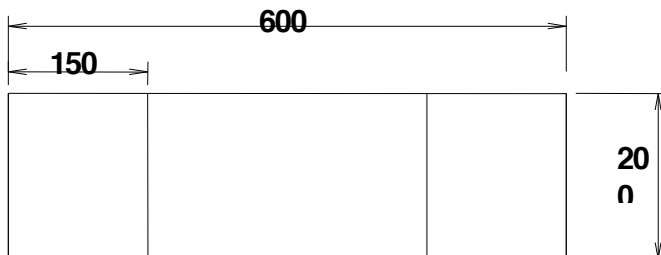

Abdeckung Teppich

Extra Carpet Cover



Assembling Instruction

**WARNING**

Any activity involving motion or height creates the possibility of serious injury including permanent paralysis and even death from landing or falling on the neck or head or other parts of the body.

You assume a risk of serious injury in using this equipment. However, the risk can be reduced by strictly following these rules at all times.

1. Use this equipment only under the supervision of a trained and qualified instructor.
2. This equipment must be used only when protected by proper matting as recommended for each piece of equipment by the International Gymnastic Federation. If doubt concerning proper matting, do not use this equipment.
3. This equipment must be used with proper spotting equipment and qualified instructors suitable to the activity or skill. Always consult an instructor.
4. Know your own limitations and the limitations of this equipment. Follow progressive learning techniques and always consult an instructor.
5. Always inspect this equipment for proper stability before each use.
6. Always inspect this equipment for loose fittings, loose cables and lock before each use. Replace any worn, defective or missing parts.
7. Always inspect this equipment for improper or unsafe installation. If in doubt, do not use this equipment.

SPIETH Gymnastic – safety in gymnastics