

INSTRUKCJA MONTAŻU

ASSEMBLY INSTRUCTION

BRAMA DO SIŁOWNI Z REGULACJĄ RĄCZEK
CABLE CROSSOVER

MP-U204

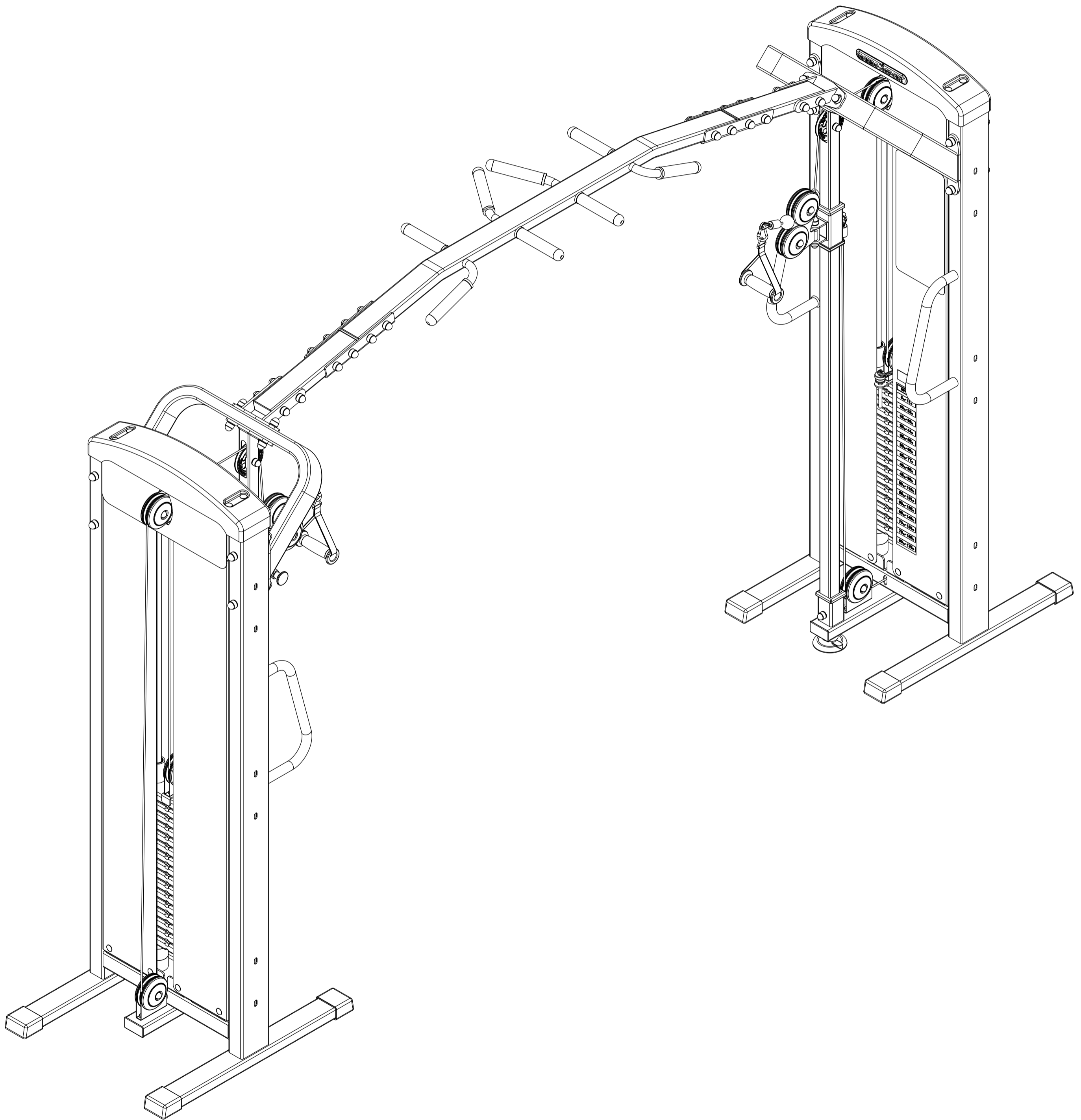

PRZED MONTAŻEM

- ▶ Przeczytaj to zanim rozpoczniesz montaż urządzenia
- ▶ Podczas montażu, podążaj zgodnie z instrukcją
- ▶ Montaż rozpocznij od pierwszego kroku kończąc na ostatnim.
- ▶ Instrukcja montażu podzielona jest na etapy (kroki), wykonuj jeden etap na raz, dopiero po jego ukończeniu, przejdź do następnego kroku.
- ▶ Jeśli podczas montażu zorientujesz się, że brakuje którejś części, poinformuj nas o tym podając jej numer.
- ▶ Aby ułatwić montaż, zastosowaliśmy w instrukcji linie montażowe.
- ▶ Urządzenie musi być sprawdzane co najmniej raz w tygodniu pod względem poziomu dokręcenia śrub, nakrętek i elementów tapicerowanych które mogą się luzować podczas użytkowania urządzenia, a także pod względem zużycia elementów obrotowych

BEFORE ASSEMBLY

- ▶ This must be read before you start assembling this unit.
- ▶ You must follow the assembly instructions exactly as outlined.
- ▶ Assemble this unit starting at the beginning and work to the end
- ▶ The assembly instructions are set out so that you are only doing one section at a time, therefore you will finish one section and move on to the next.
- ▶ If something is missing when assembling this unit, you must notify us of the part number of the exact nut, bolt or part that is missing.
- ▶ To help you assemble this unit we have used line drawings.
- ▶ Check the line drawings for the exact positioning of the parts.
- ▶ The unit will need to be checked at least once a week for nuts and bolts that can work loose, upholstered pieces working loose and wear on pivot assemblies.

POTRZEBNE NARZĘDZIA / TOOLS NEEDED

MŁOTEK GUMOWY
RUBBER HAMMER



KLUCZ OCZKOWY
KEY FLAT EYE
2x19 / 2x10 /



KLUCZ IMBUSOWY
HEX KEY
10 / 5



KROK 1 / STEP 1

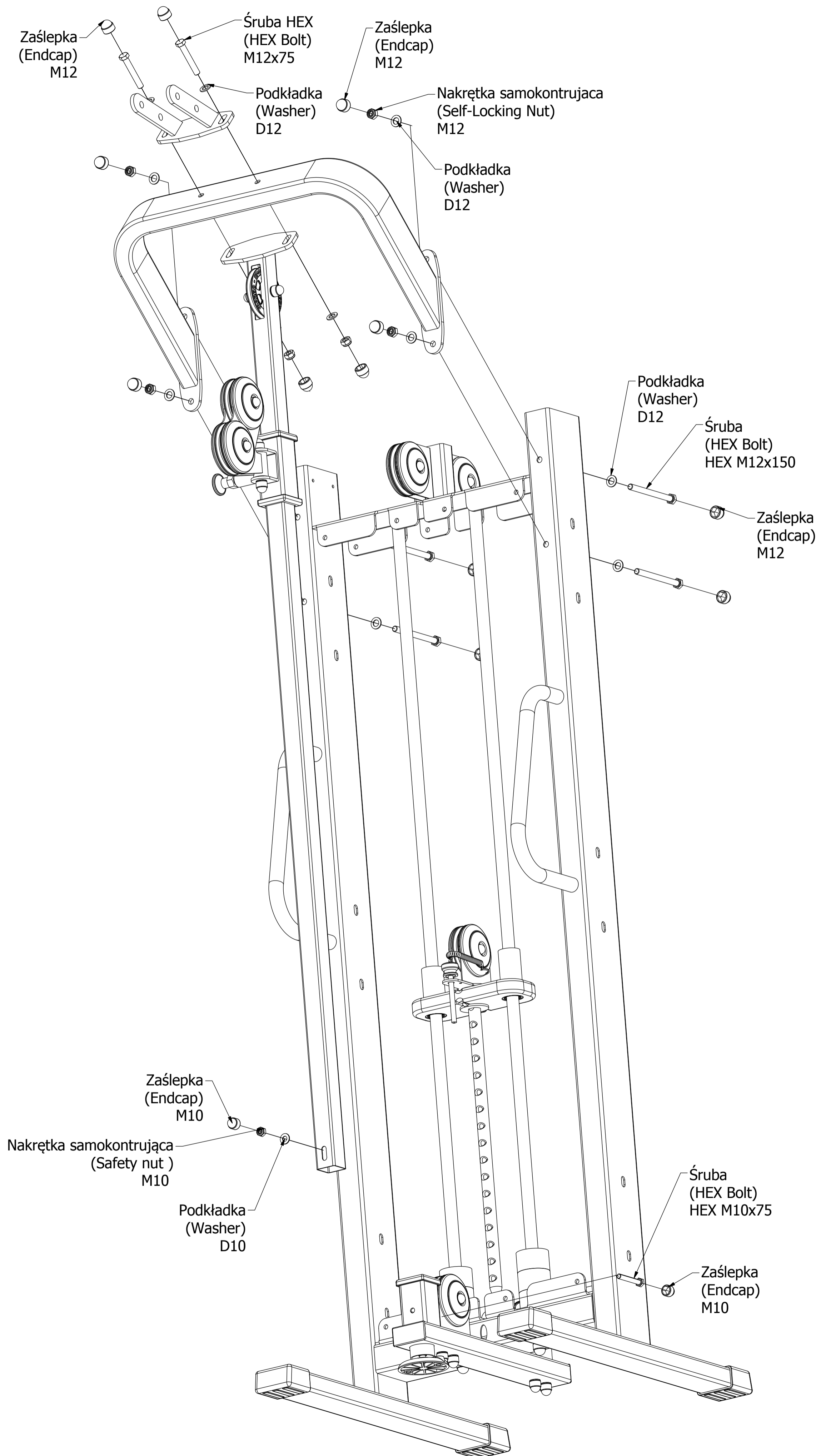

KROK 2 / STEP 2

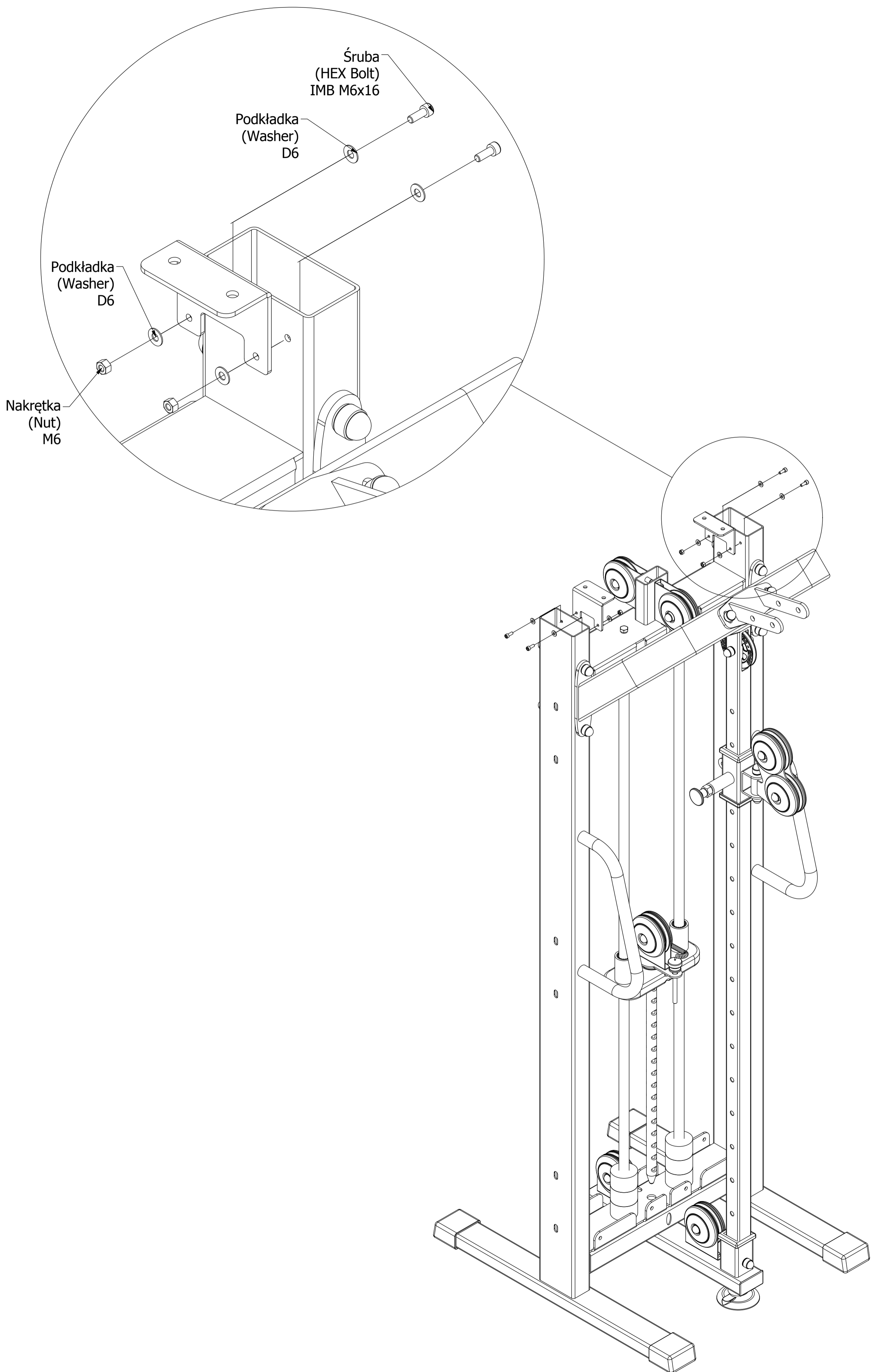

KROK 3/ STEP 3

3a

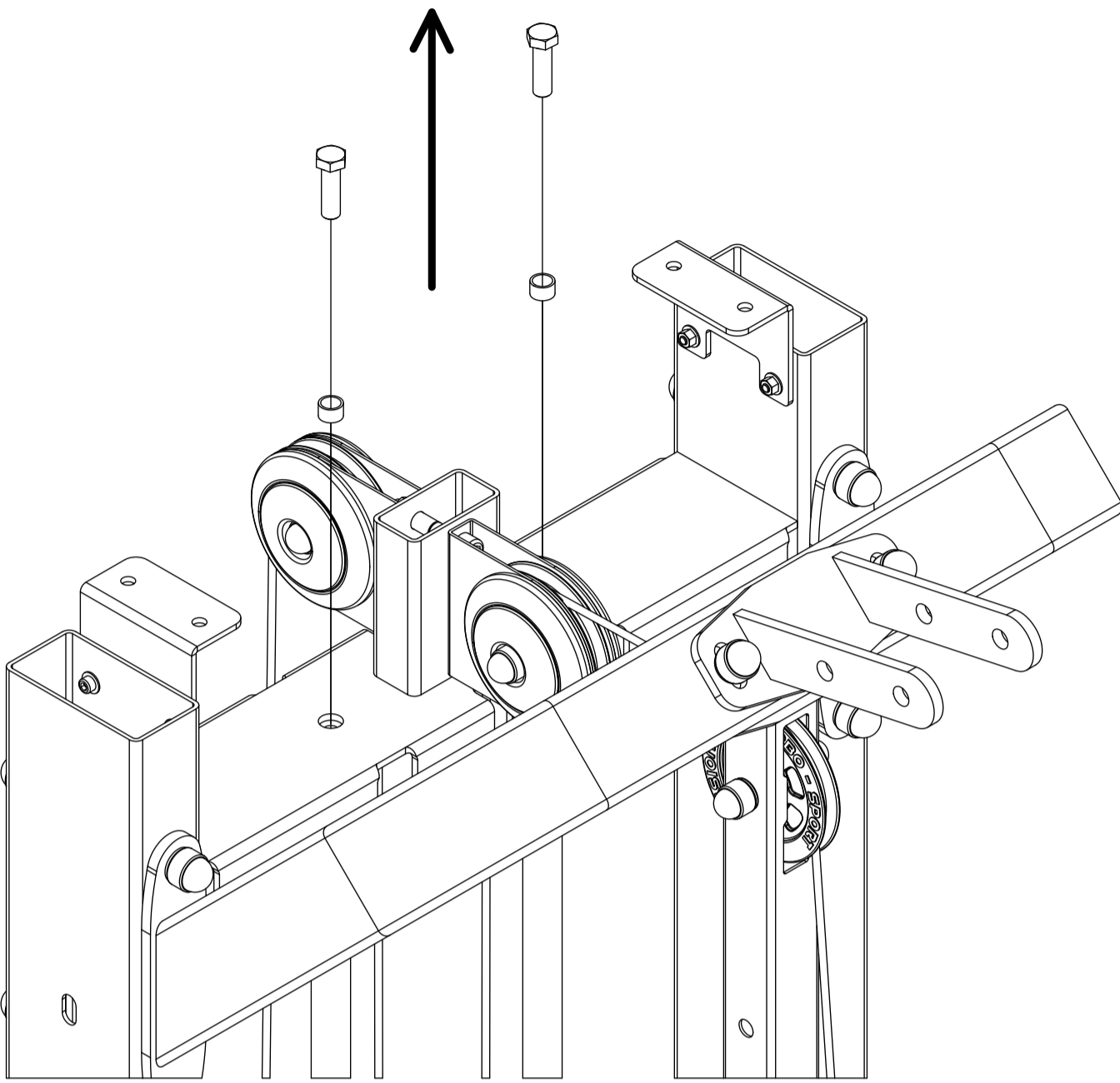

3b

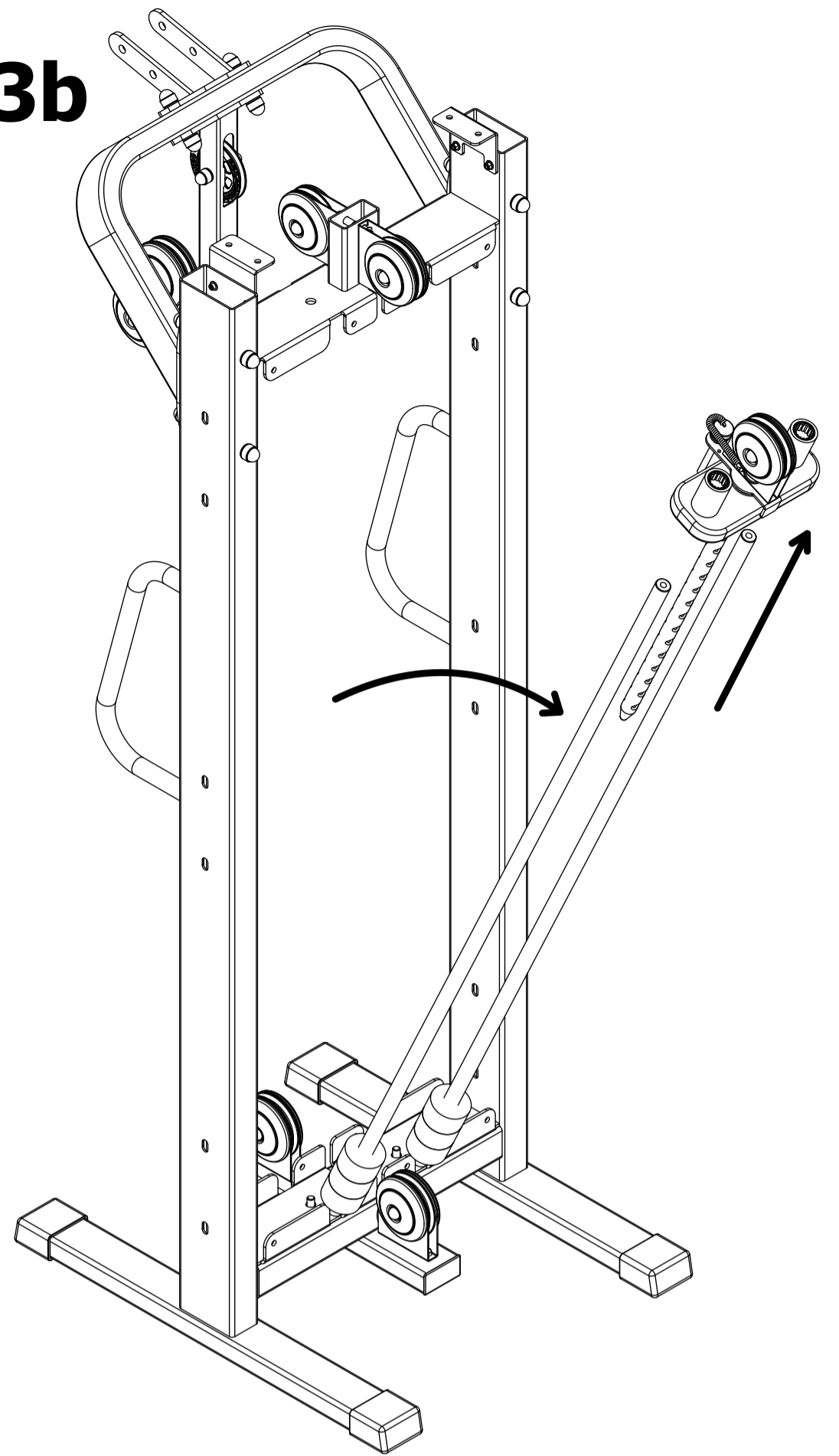

3c

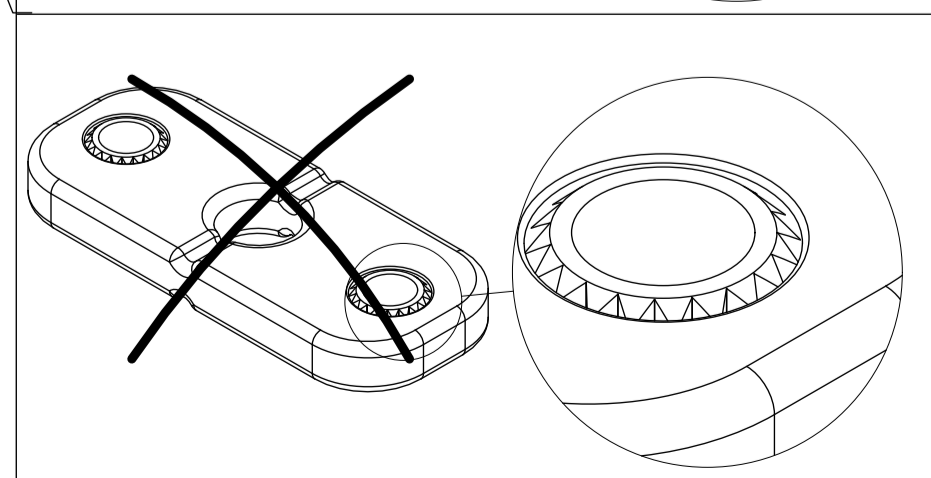
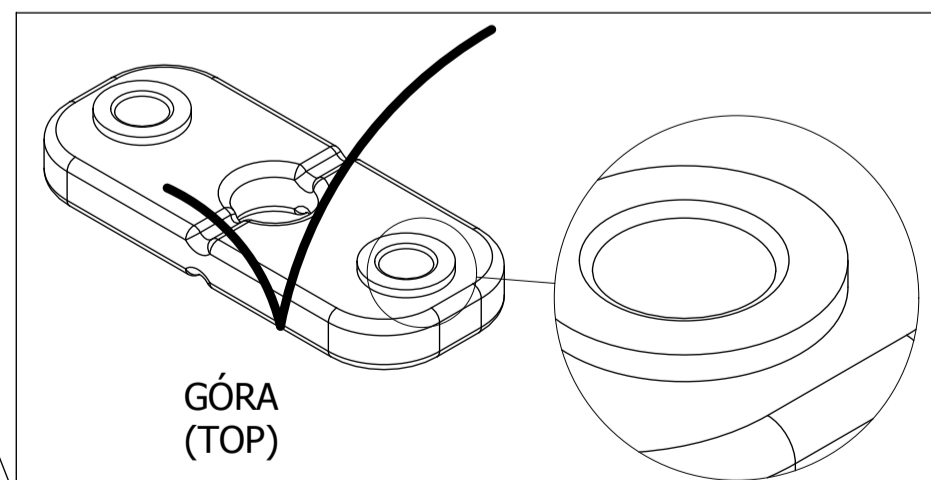
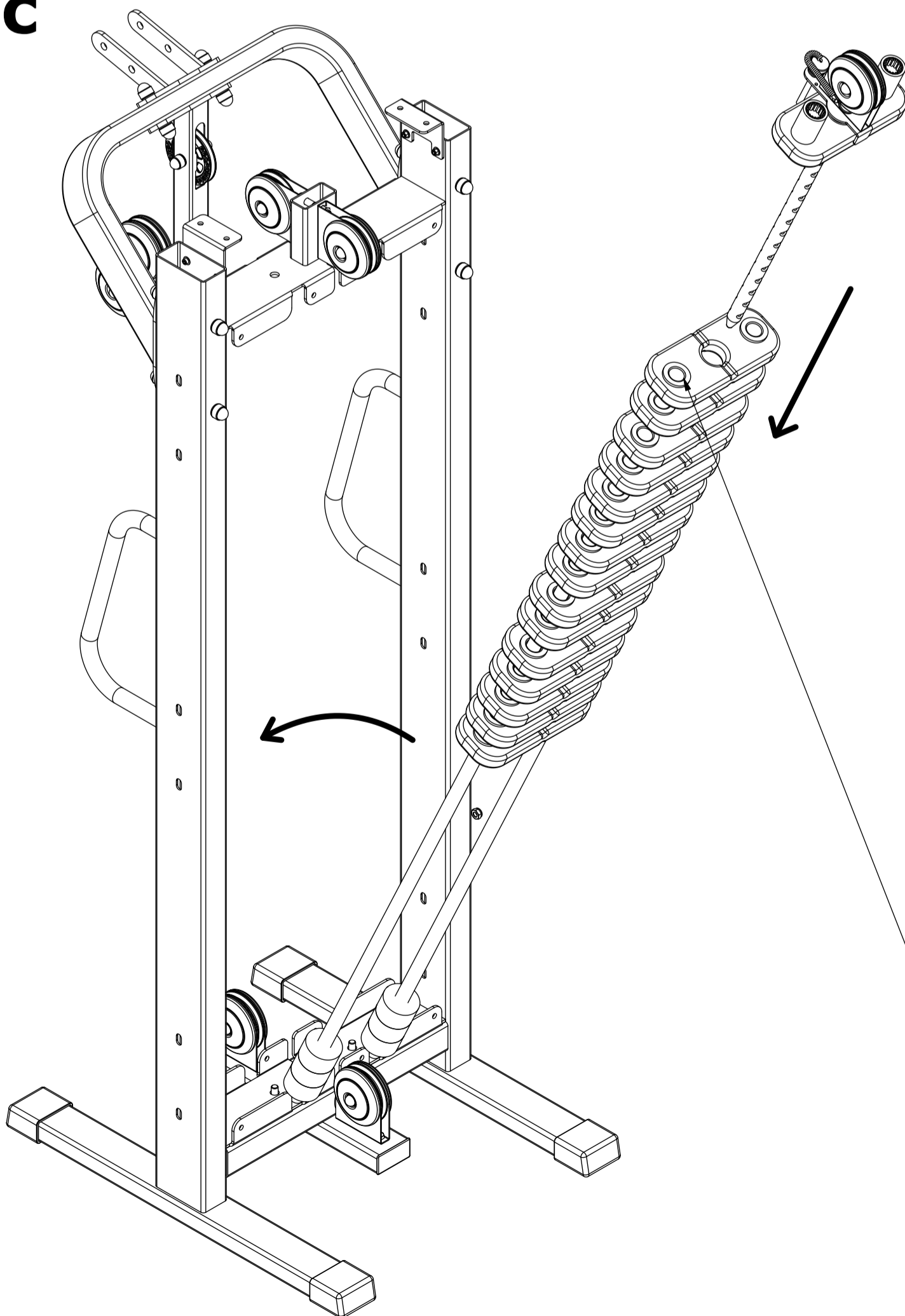

**UWAGA!
ATTENTION!**



Sztaby w stosach umieszczają naprzemian literą/logo "F"

(Weights in stack are inserted alternately "F" letter/logo)

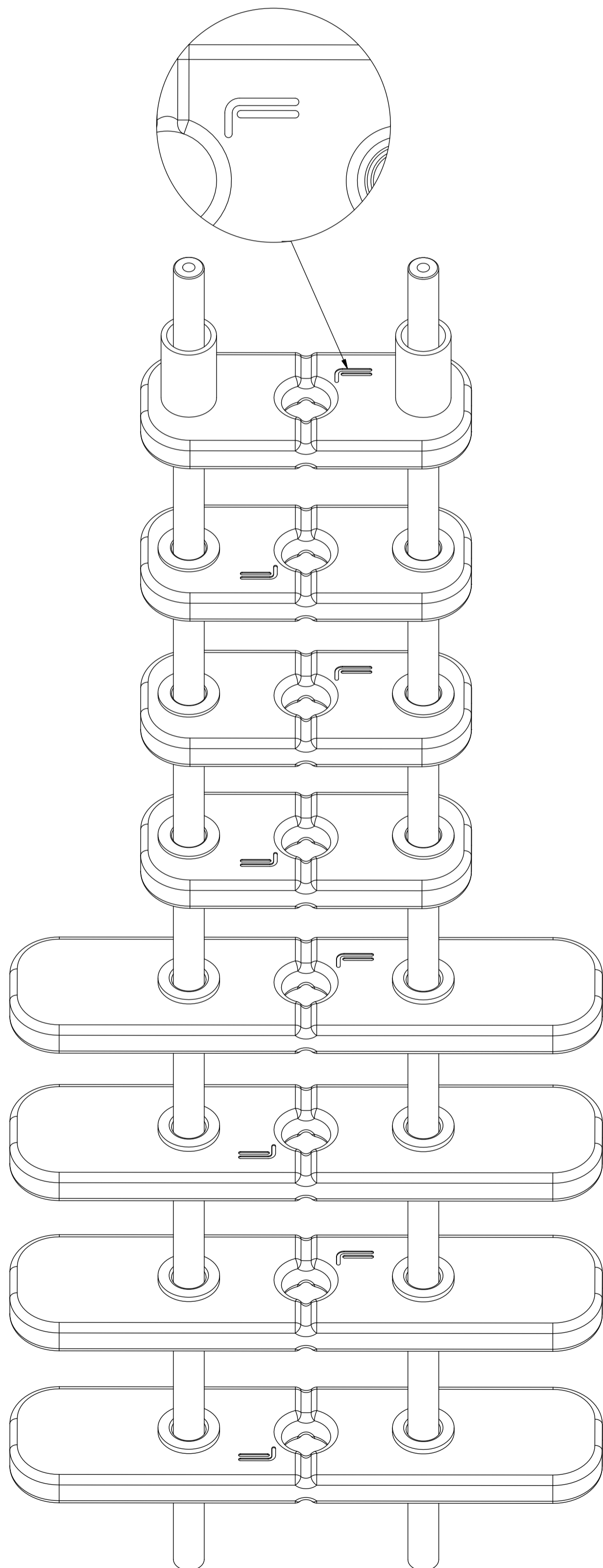

Sztaby montuj zgodnie z numeracją

(Mount all weights according to the numbering)

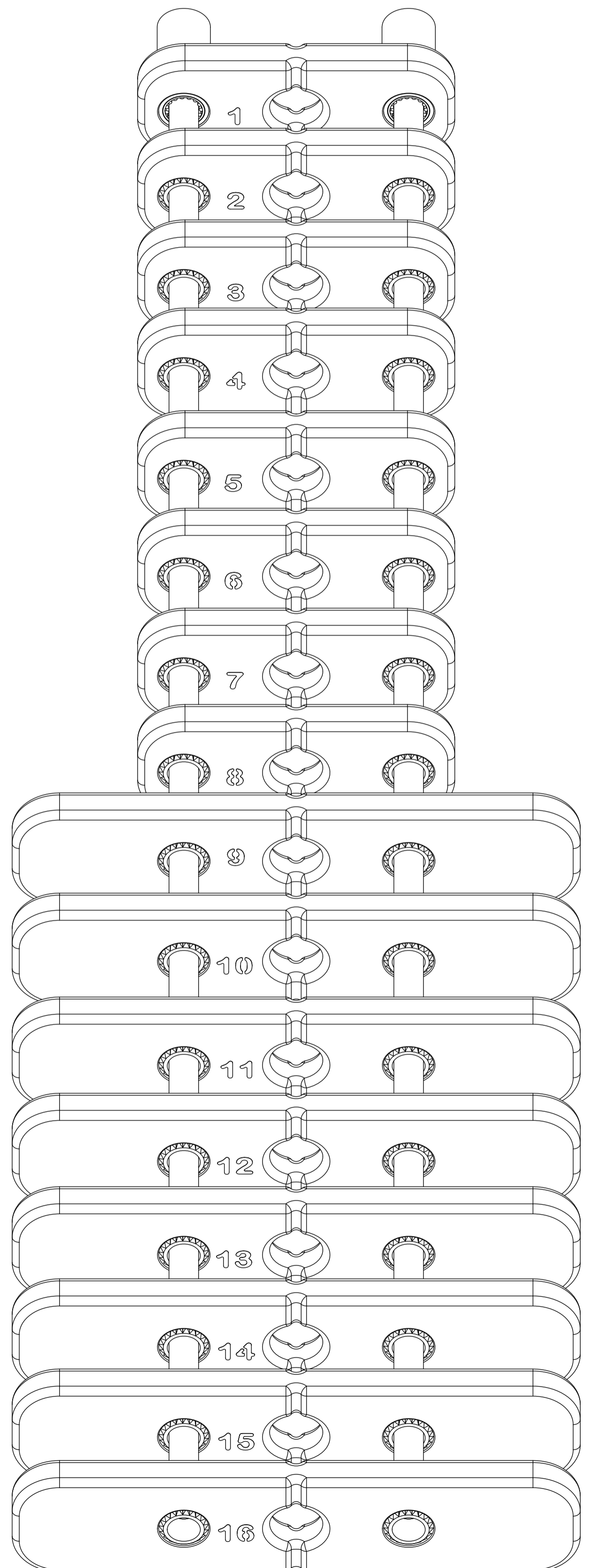

KROK 4/ STEP 4

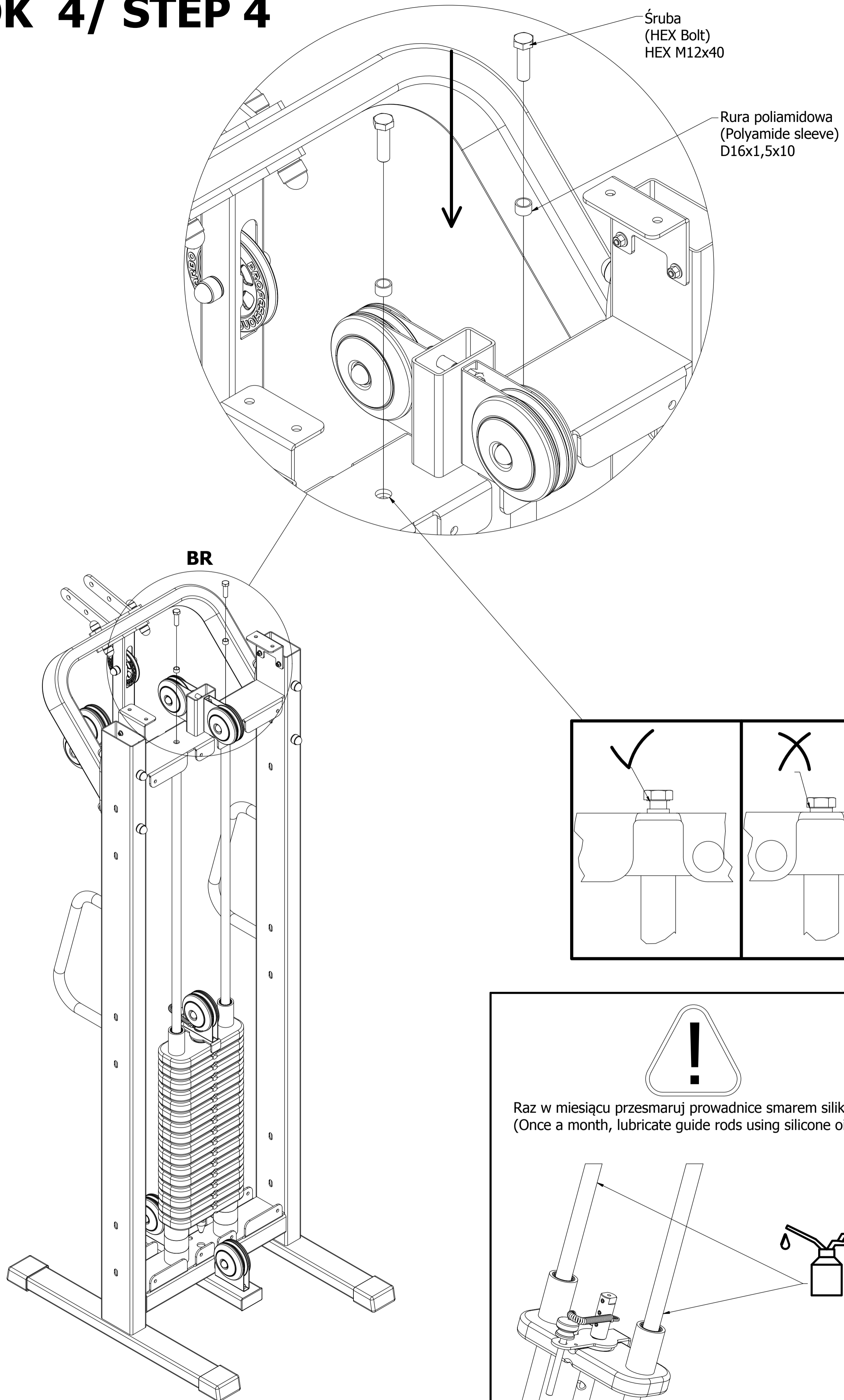

KROK 5 / STEP 5

MONTAŻ LINKI (CABLE ROUTING)

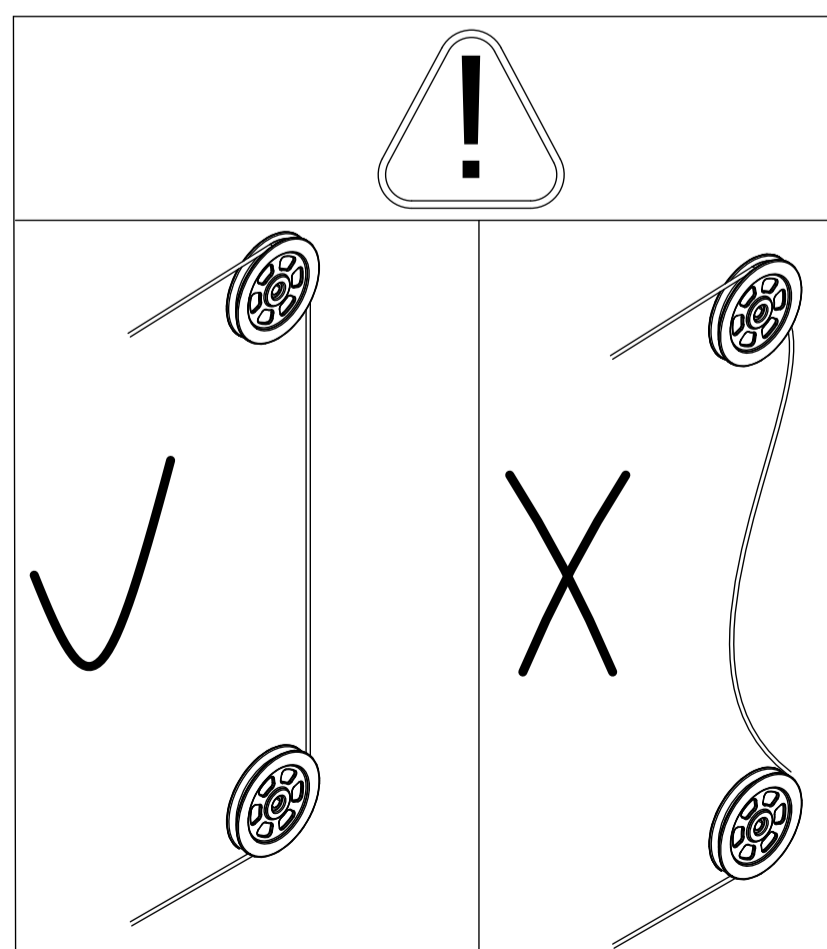
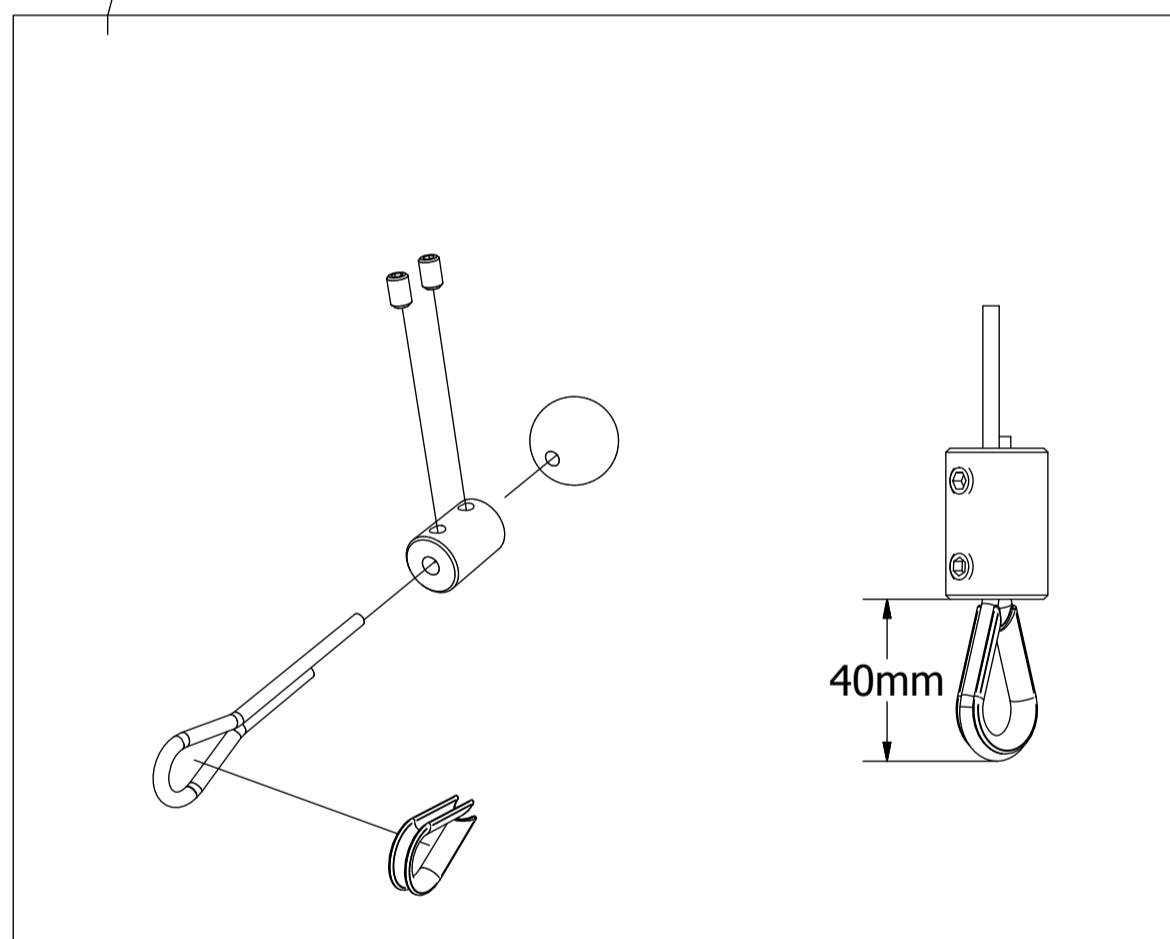
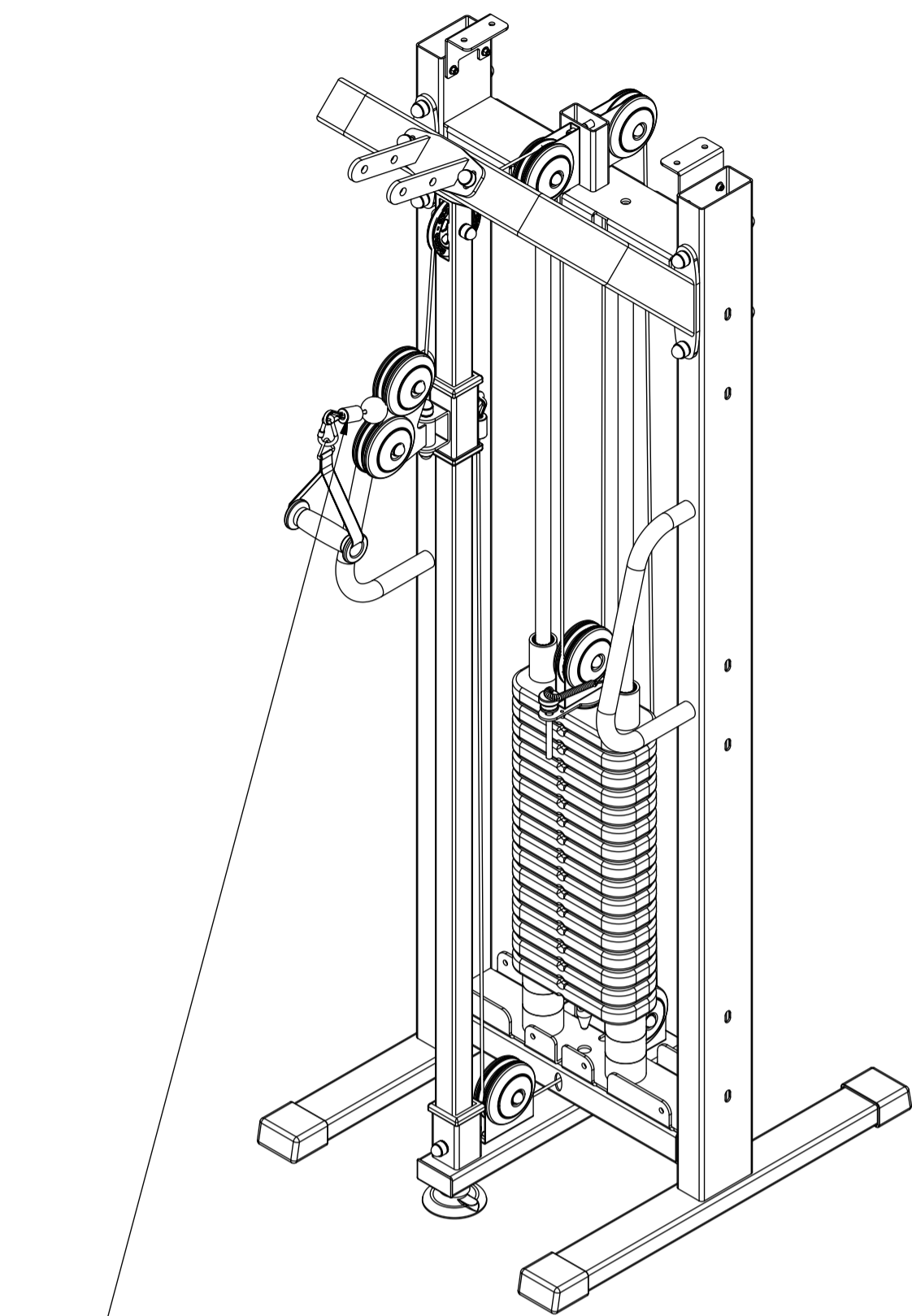
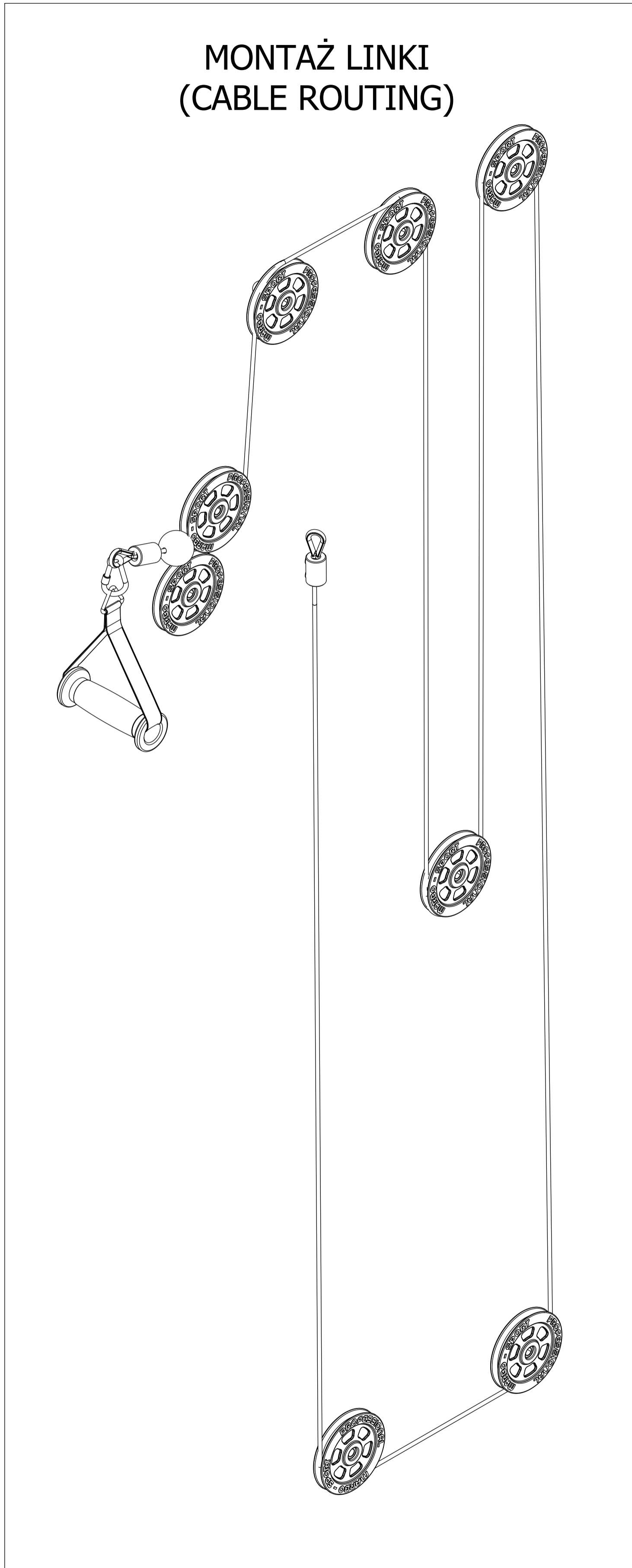

KROK 6 / STEP 6

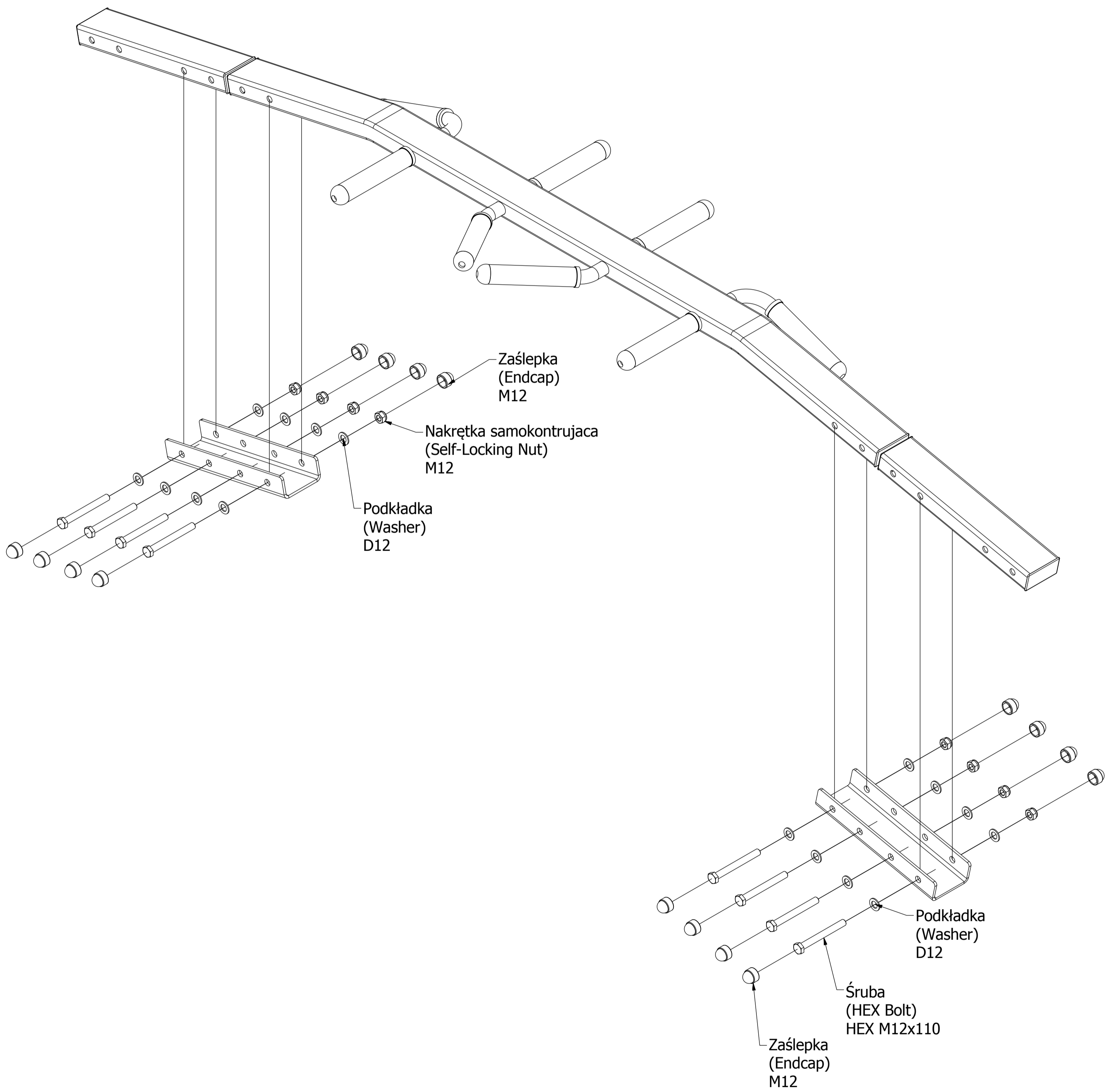

KROK 7 / STEP 7

Spinka rozporowa
(Fastener)
D9,5

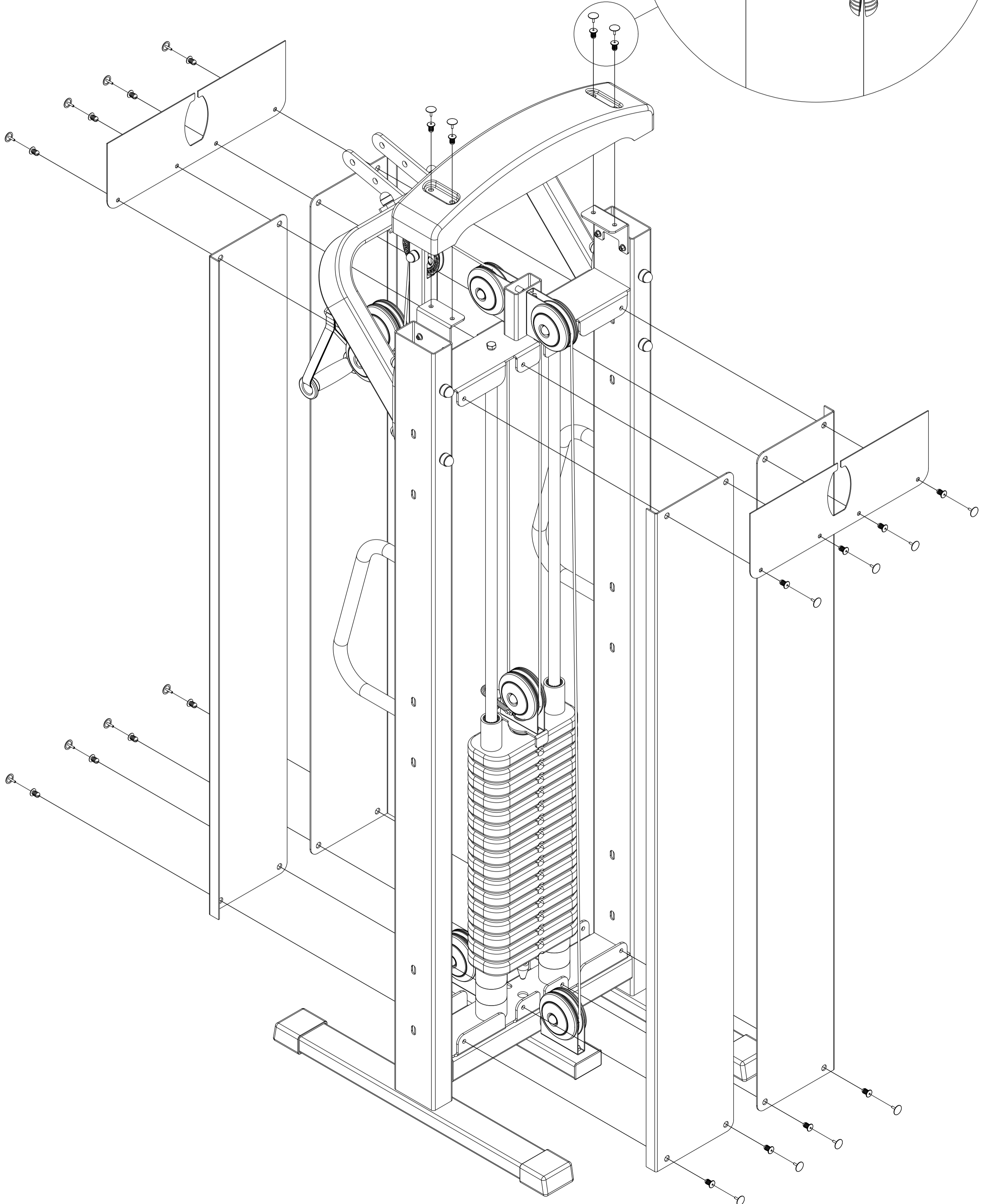
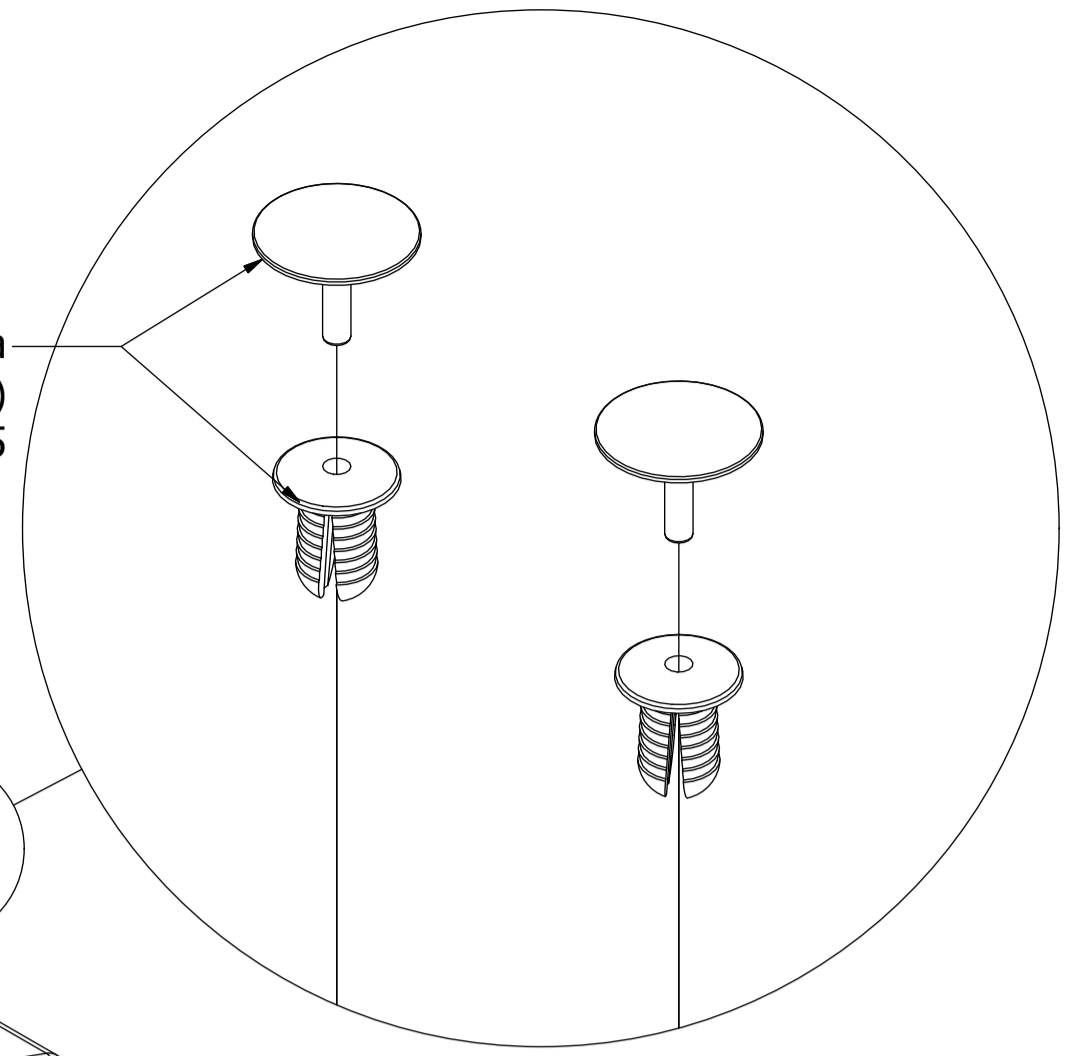

KROK 8 / STEP 8

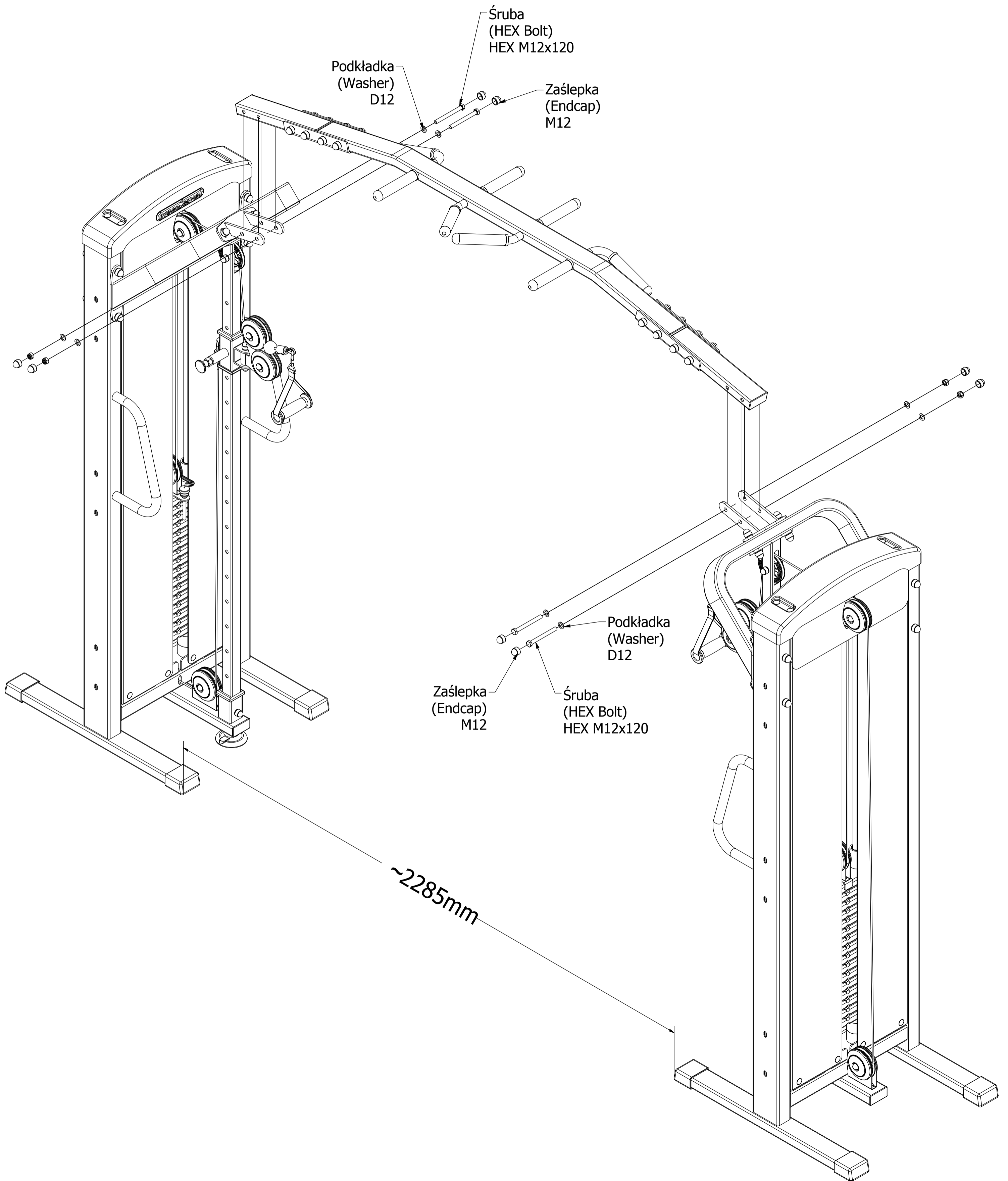

KROK 9 / STEP 9

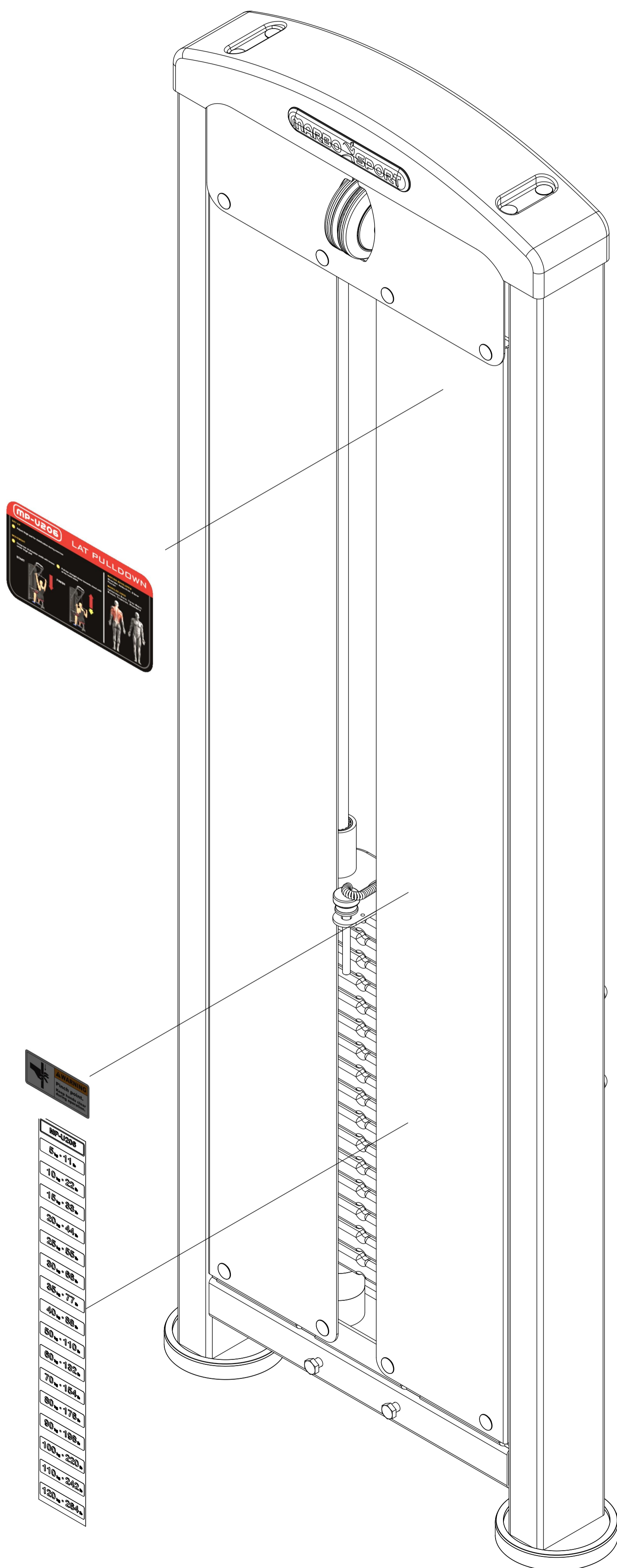

x2

- | mp-u206 |
|-----------|
| 8 • 11 |
| 10 • 22 |
| 18 • 28 |
| 20 • 44 |
| 28 • 56 |
| 30 • 66 |
| 38 • 77 |
| 40 • 88 |
| 50 • 110 |
| 60 • 132 |
| 70 • 154 |
| 80 • 176 |
| 90 • 198 |
| 100 • 220 |
| 110 • 242 |
| 120 • 264 |